

Triclad EnduroClad

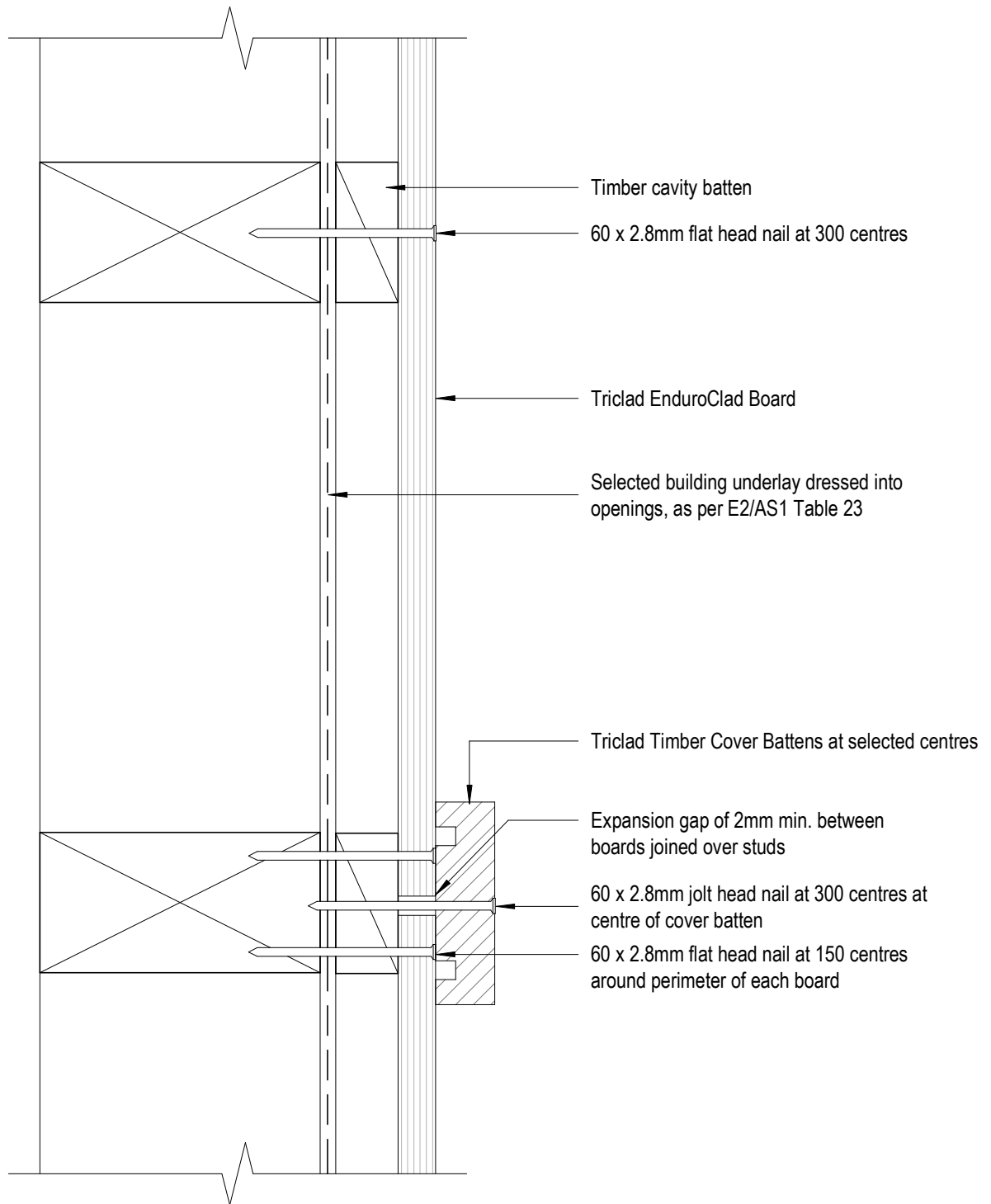

TRICLAD
CLADDING SYSTEMS

8 Quail Place
Hamilton Lake
Hamilton
New Zealand

Cavity Fix Nailing Setout Detail

T. 0800 874 2523

E. sales@triclad.co.nz

www.triclad.co.nz

1 : 2 @ A4
Scale

Dec 2019
Date

Fig 1
Dwg

Triclad EnduroClad

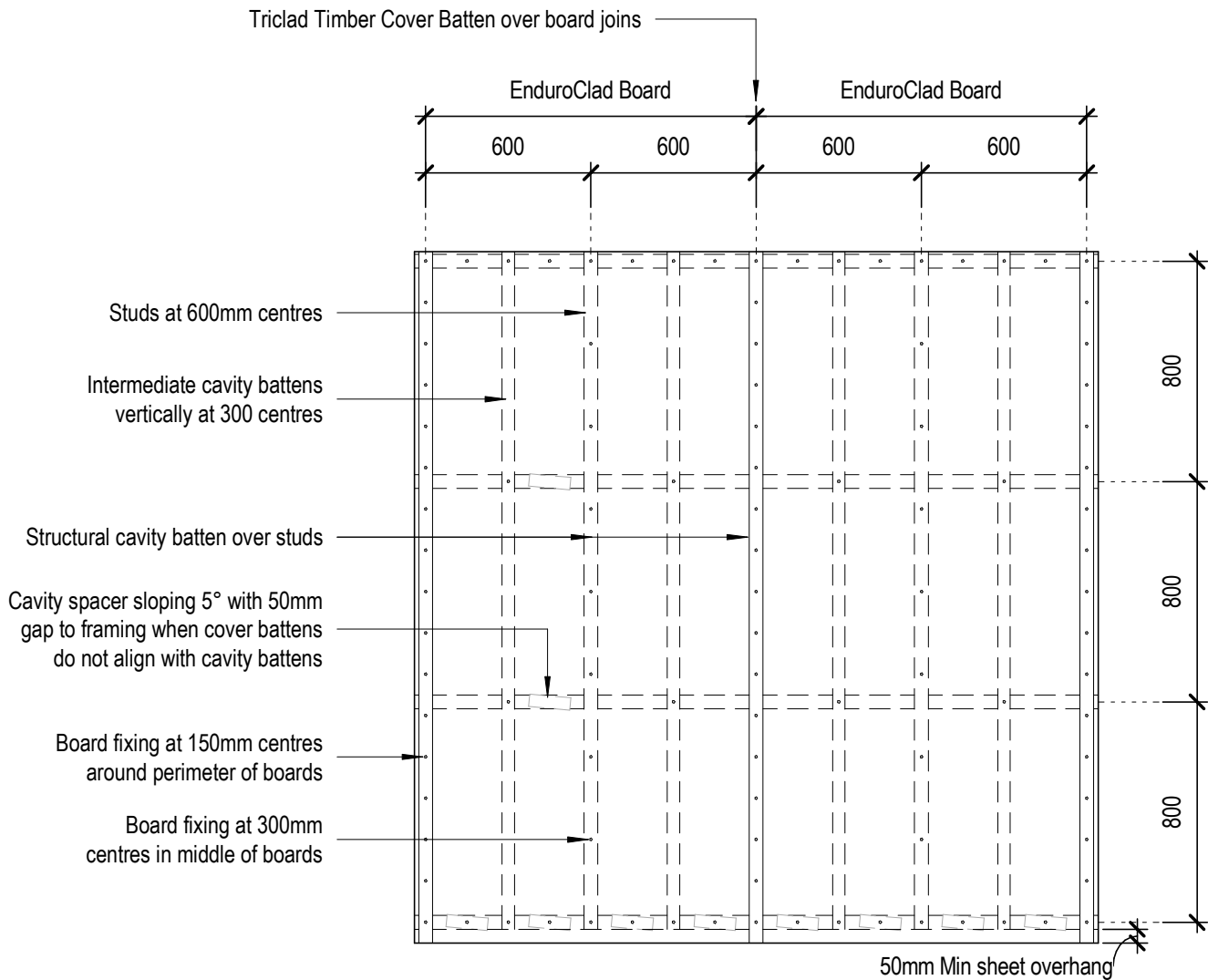

NOTE:

Where cover battens do not sit over a stud it is recommended that additional noggling is used to provide additional fixing for the decorative cover battens.



TRICLAD
CLADDING SYSTEMS

8 Quail Place
Hamilton Lake
Hamilton
New Zealand

Cavity Fix Framing/Batten Setout-600mm

T. 0800 874 2523

E. sales@triclad.co.nz

www.triclad.co.nz

1 : 25 @ A4
Scale

Dec 2019
Date

Fig 2a
Dwg

Triclad EnduroClad

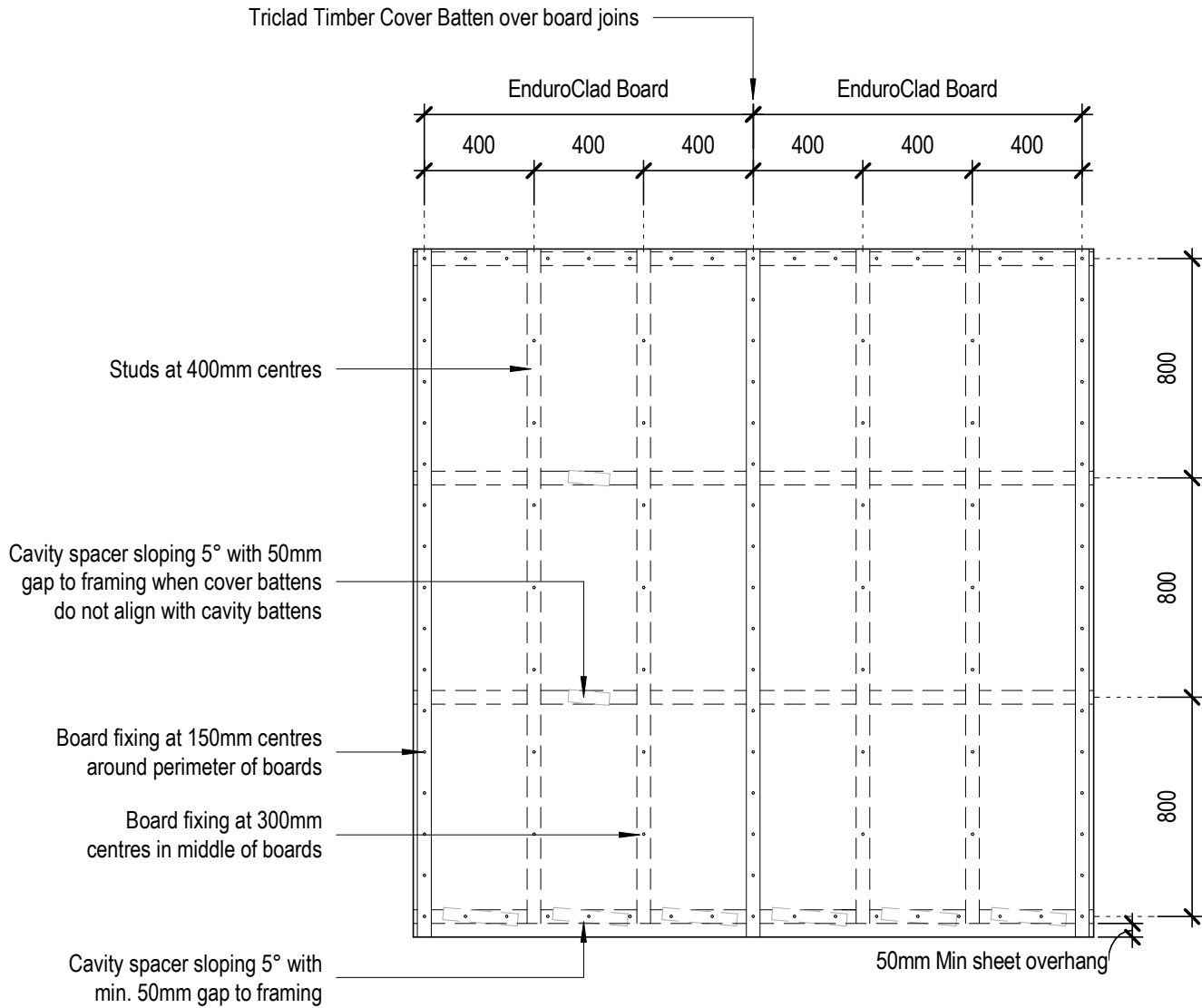

NOTE:

Where cover battens do not sit over a stud it is recommended that additional noggling is used to provide additional fixing for the decorative cover battens.



TRICLAD
CLADDING SYSTEMS

8 Quail Place
Hamilton Lake
Hamilton
New Zealand

**Cavity Fix
Framing/Batten Setout-400mm**

T. 0800 874 2523

E. sales@triclad.co.nz

www.triclad.co.nz

1 : 25 @ A4
Scale

Dec 2019
Date

Fig 2b
Dwg

Triclad EnduroClad

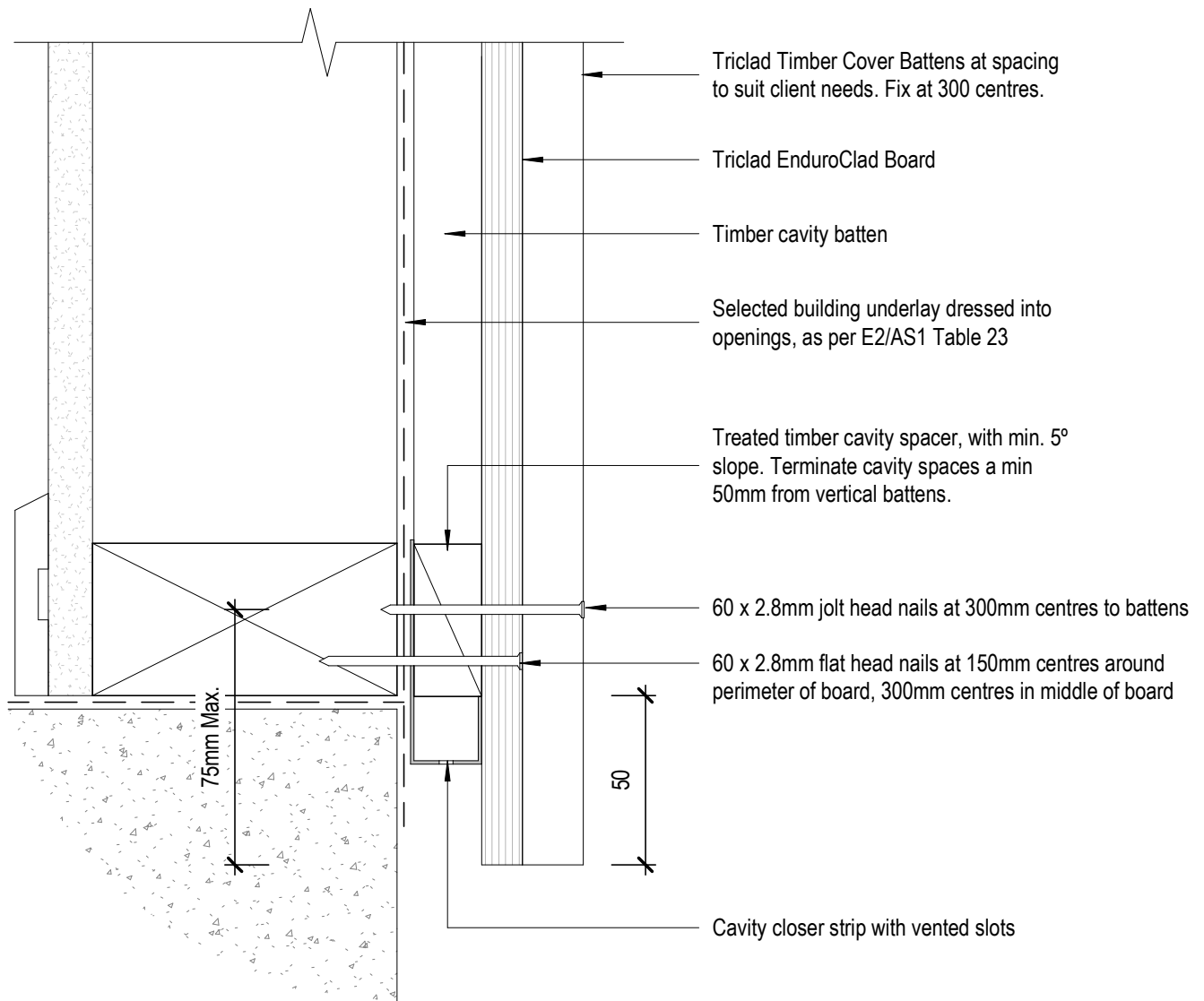

NOTE:
Ground clearances to bottom of cladding as per NZS3604:2011



8 Quail Place
Hamilton Lake
Hamilton
New Zealand

Cavity Fix Base Detail-Concrete Floor

T. 0800 874 2523

E. sales@triclad.co.nz

www.triclad.co.nz

1 : 2 @ A4
Scale

Dec 2019
Date

Fig 3
Dwg

Triclاد EnduroClad

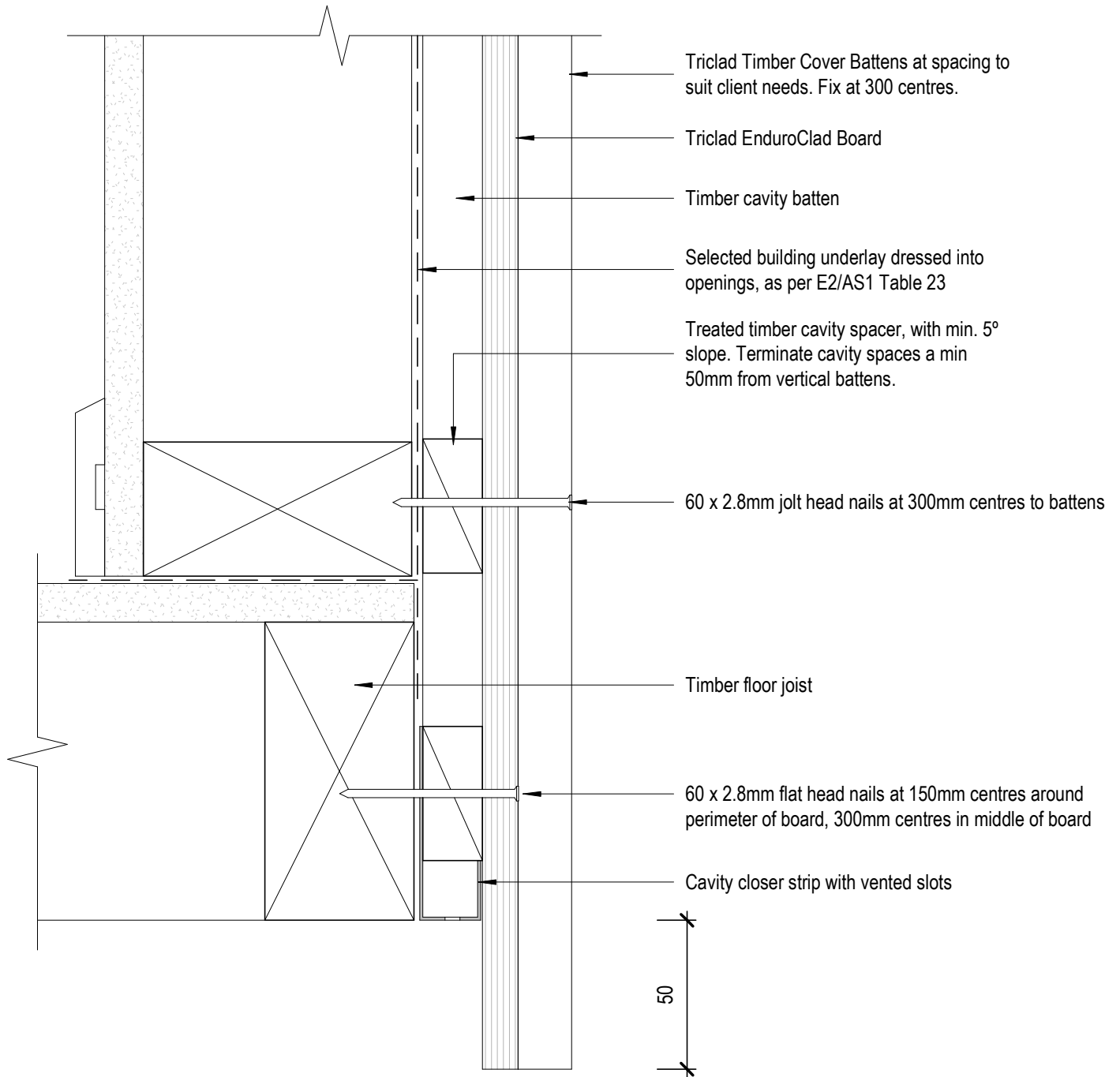

TRICLAD
CLADDING SYSTEMS

8 Quail Place
Hamilton Lake
Hamilton
New Zealand

Cavity Fix Base Detail-Timber Floor

T. 0800 874 2523

E. sales@triclاد.co.nz

www.triclاد.co.nz

1 : 2 @ A4
Scale

Dec 2019
Date

Fig 4
Dwg

Triclad EnduroClad

Non-Corner Flashing Optional Detail:

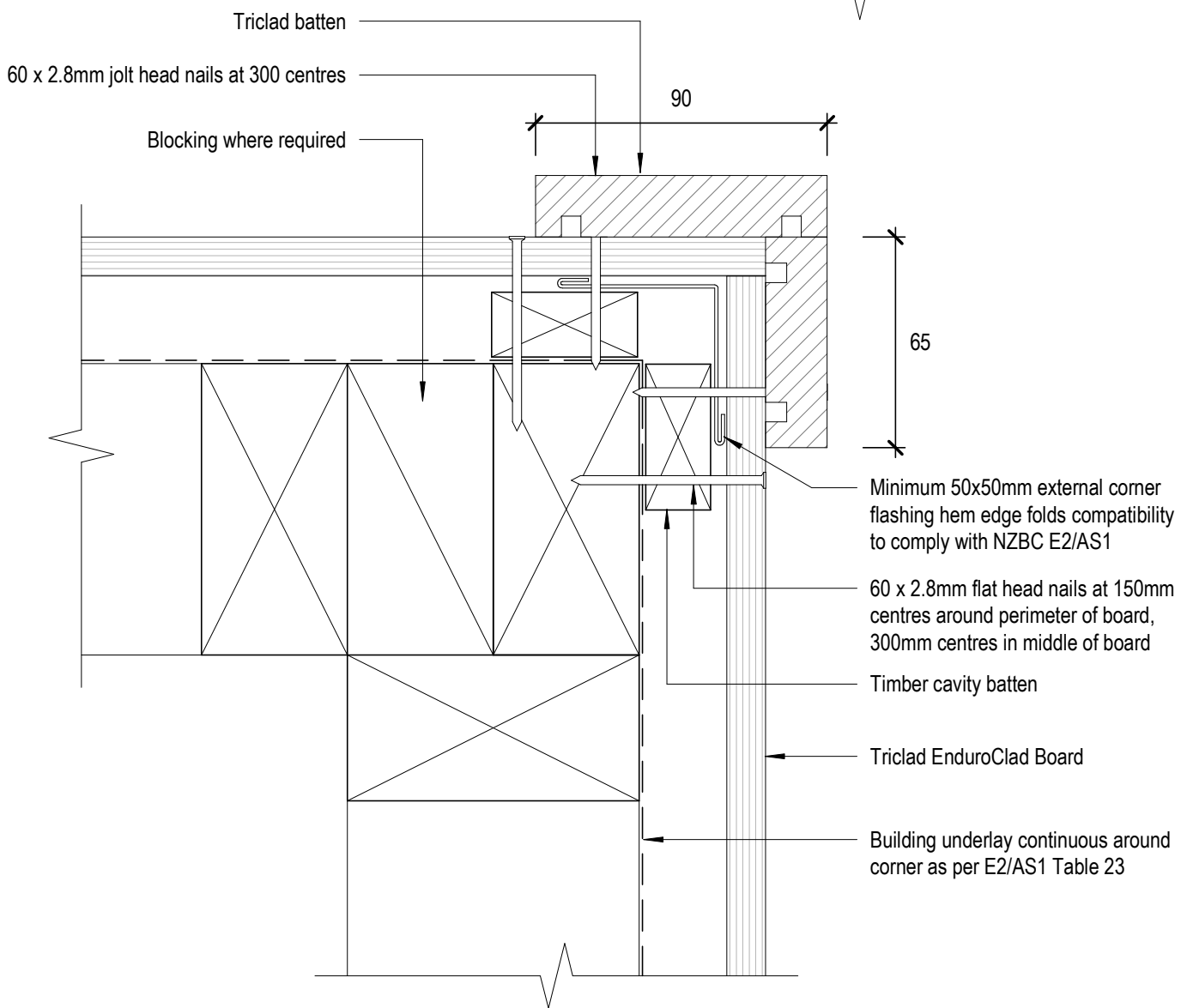
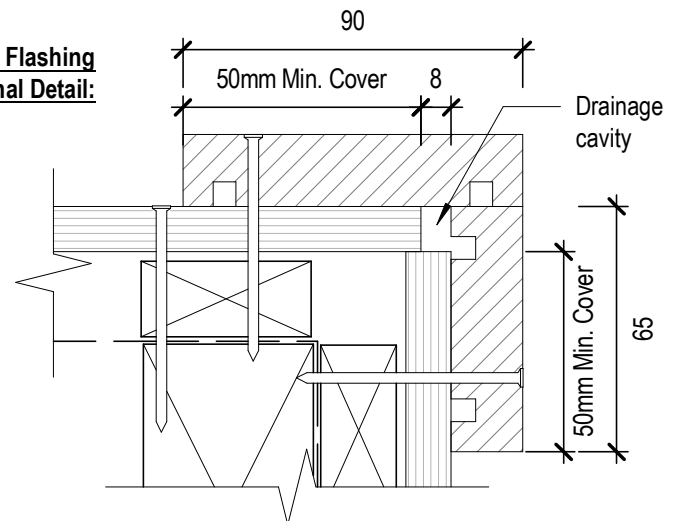

TRICLAD
CLADDING SYSTEMS

8 Quail Place
Hamilton Lake
Hamilton
New Zealand

Cavity Fix External Corner-Boxed

T. 0800 874 2523

E. sales@triclad.co.nz

www.triclad.co.nz

1 : 2 @ A4
Scale

Dec 2019
Date

Fig 5
Dwg

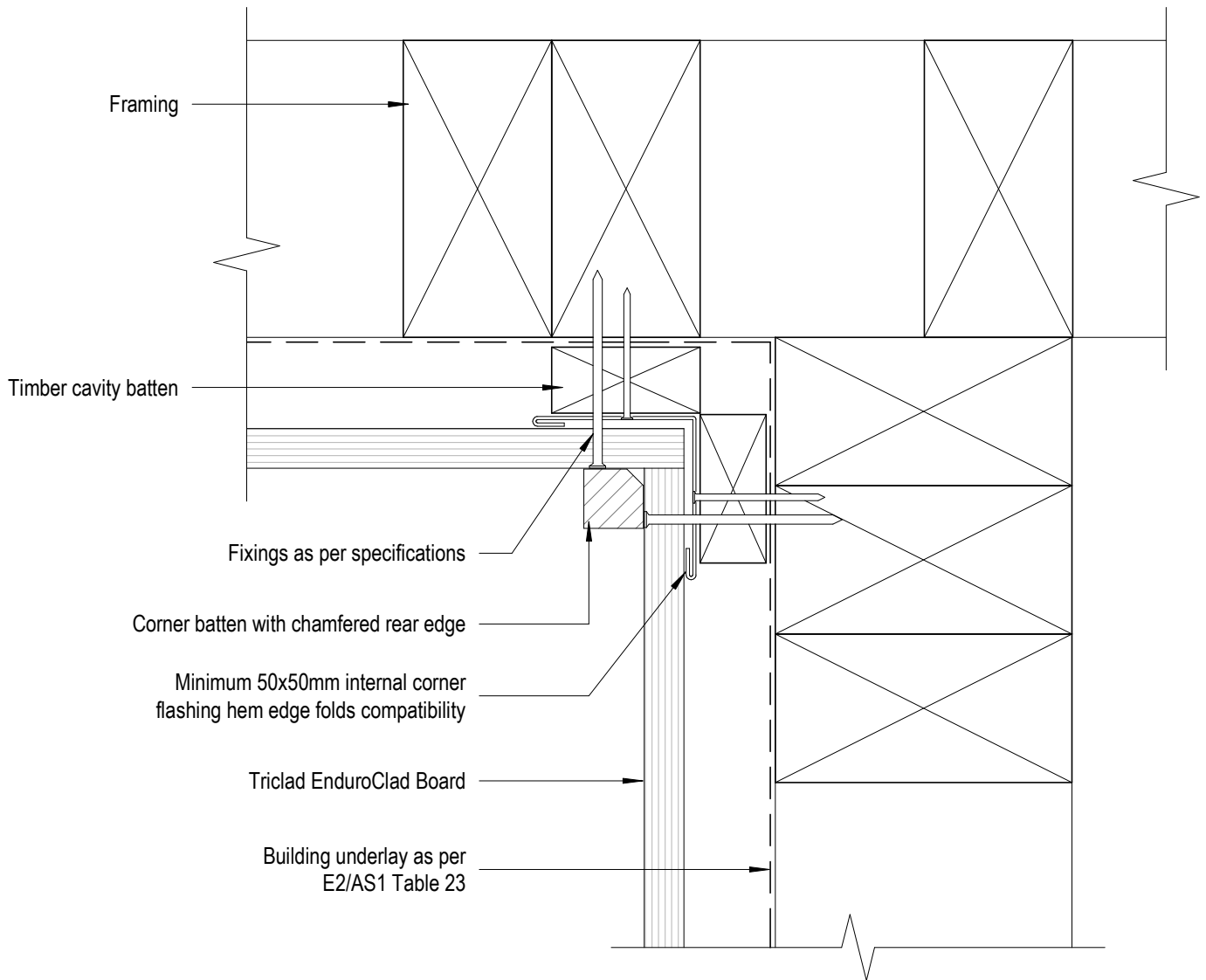

TRICLAD
CLADDING SYSTEMS

8 Quail Place
Hamilton Lake
Hamilton
New Zealand

Cavity Fix Internal Corner

Triclad EnduroClad

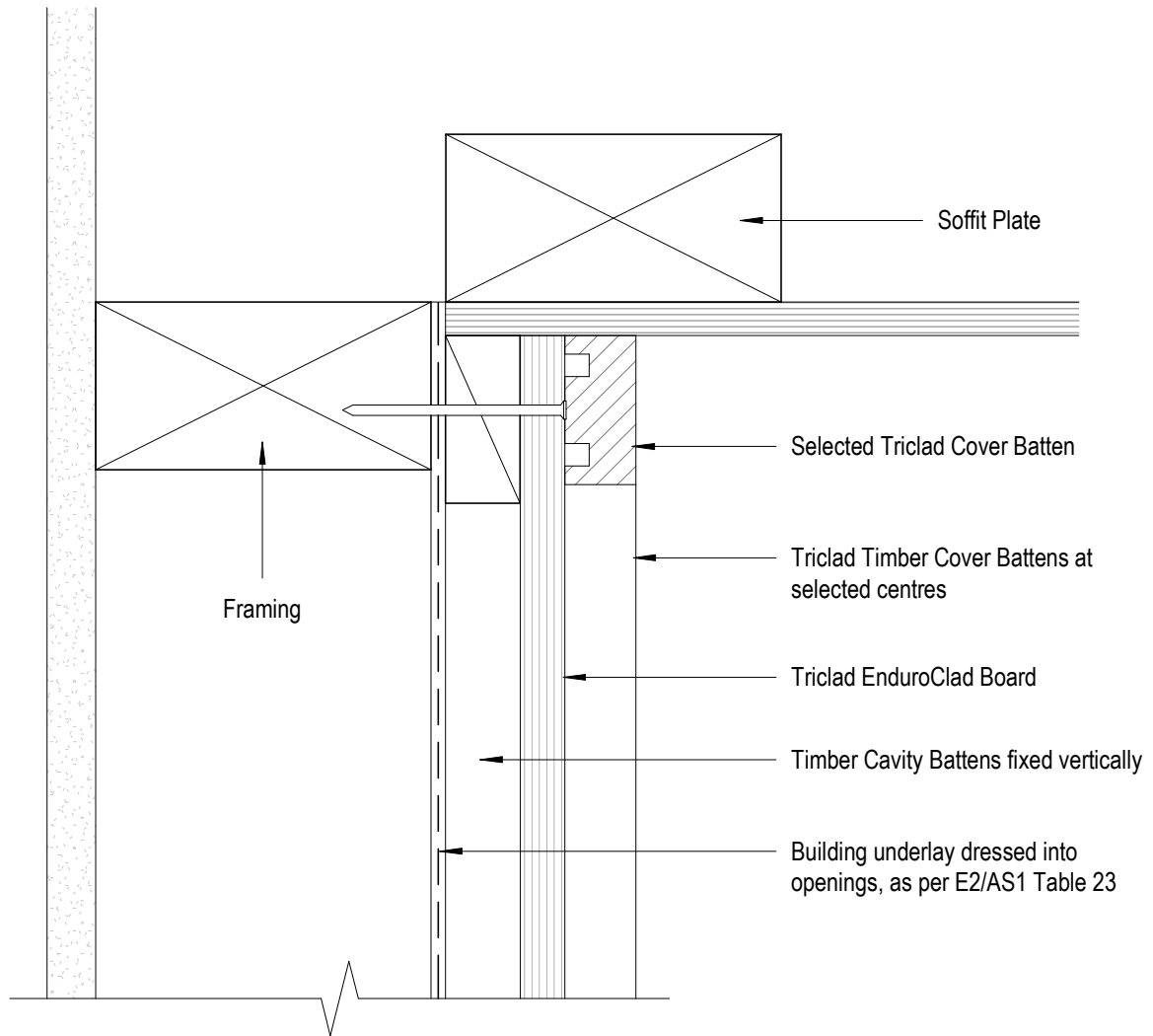

TRICLAD
CLADDING SYSTEMS

8 Quail Place
Hamilton Lake
Hamilton
New Zealand

Cavity Fix Soffit Detail

T. 0800 874 2523

E. sales@triclad.co.nz

www.triclad.co.nz

1 : 2 @ A4
Scale

Dec 2019
Date

Fig 7
Dwg

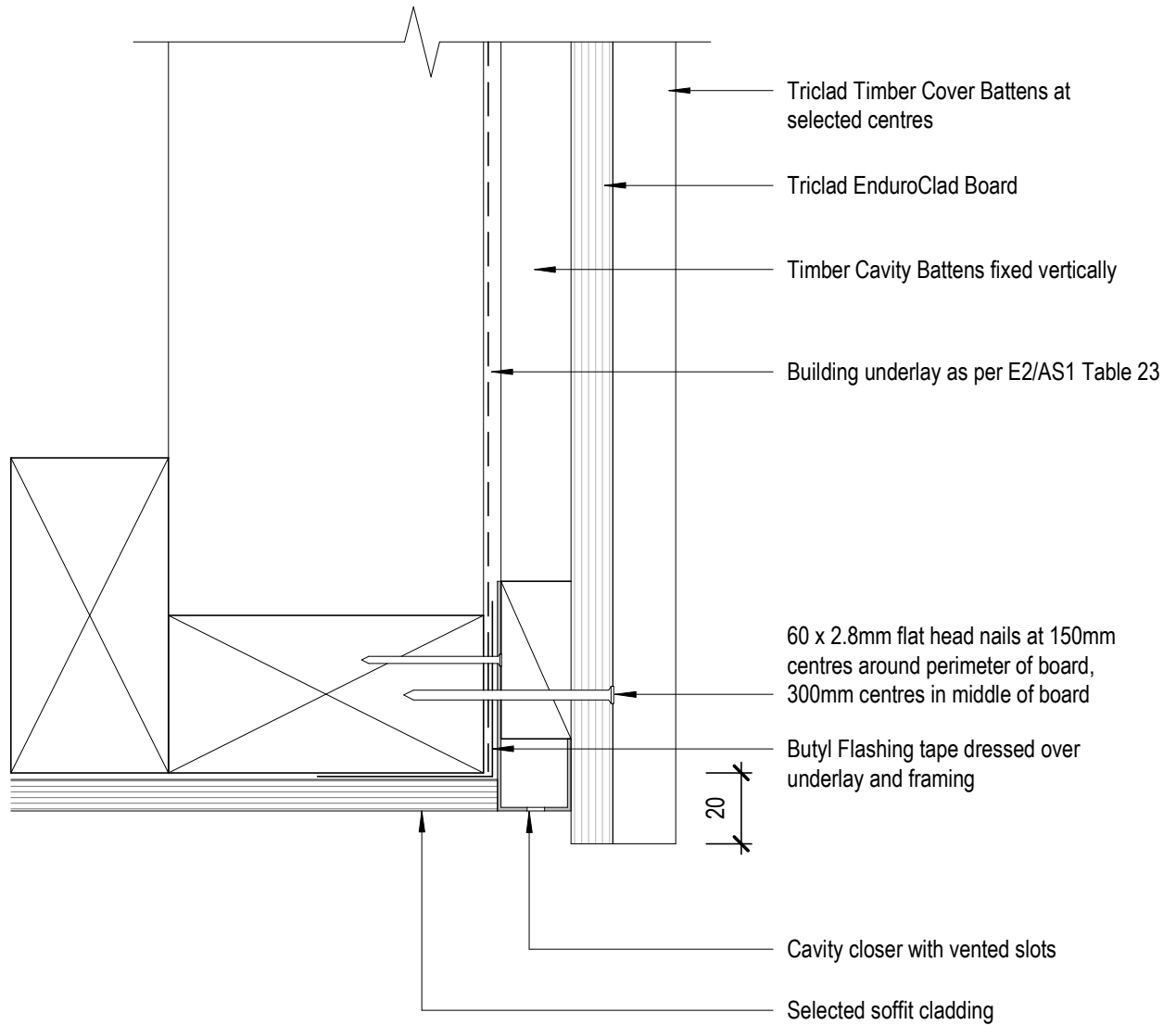

TRICLAD
CLADDING SYSTEMS

8 Quail Place
Hamilton Lake
Hamilton
New Zealand

Cavity Fix Soffit/Beam Detail

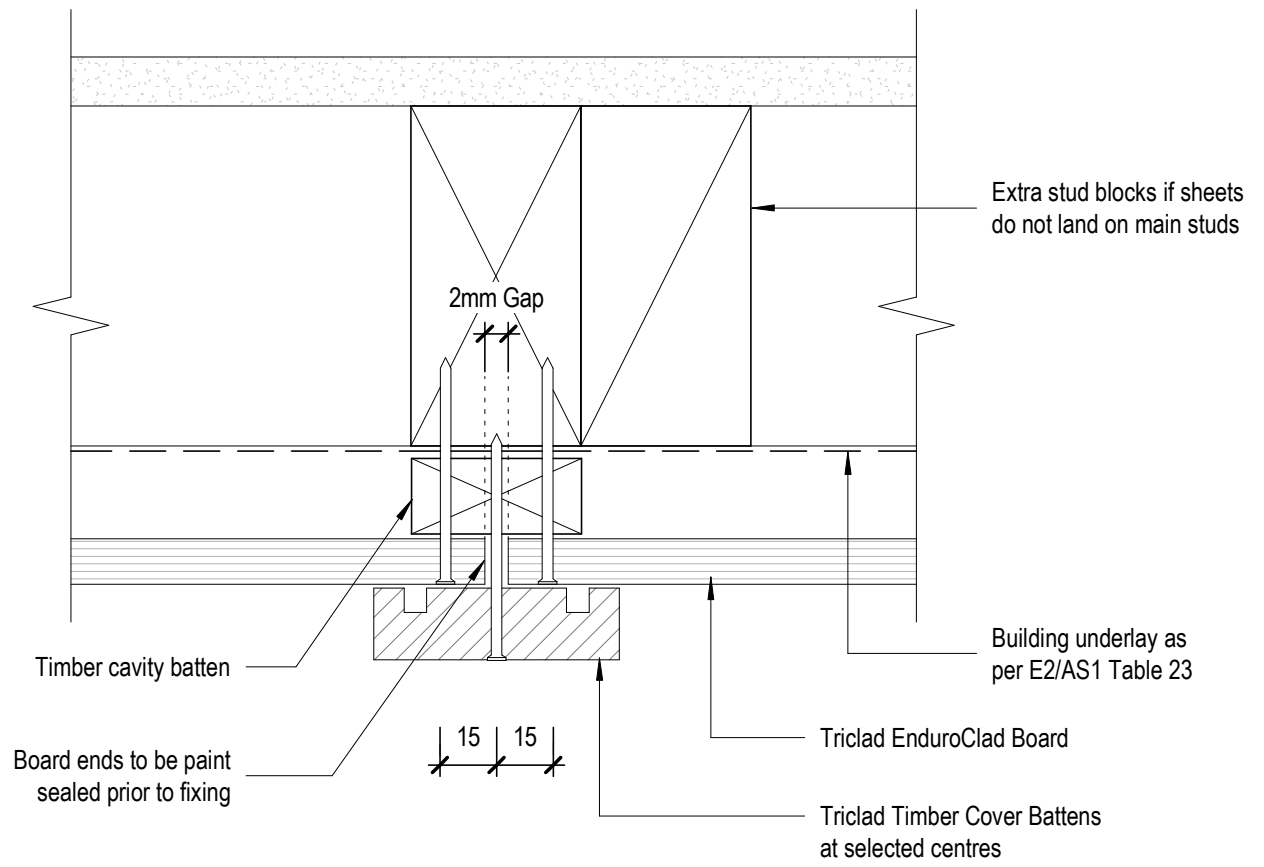

TRICLAD
CLADDING SYSTEMS

8 Quail Place
Hamilton Lake
Hamilton
New Zealand

Cavity Fix Board Joint Detail

T. 0800 874 2523

E. sales@triclad.co.nz

www.triclad.co.nz

1 : 2 @ A4
Scale

Dec 2019
Date

Fig 9
Dwg

Triclad EnduroClad

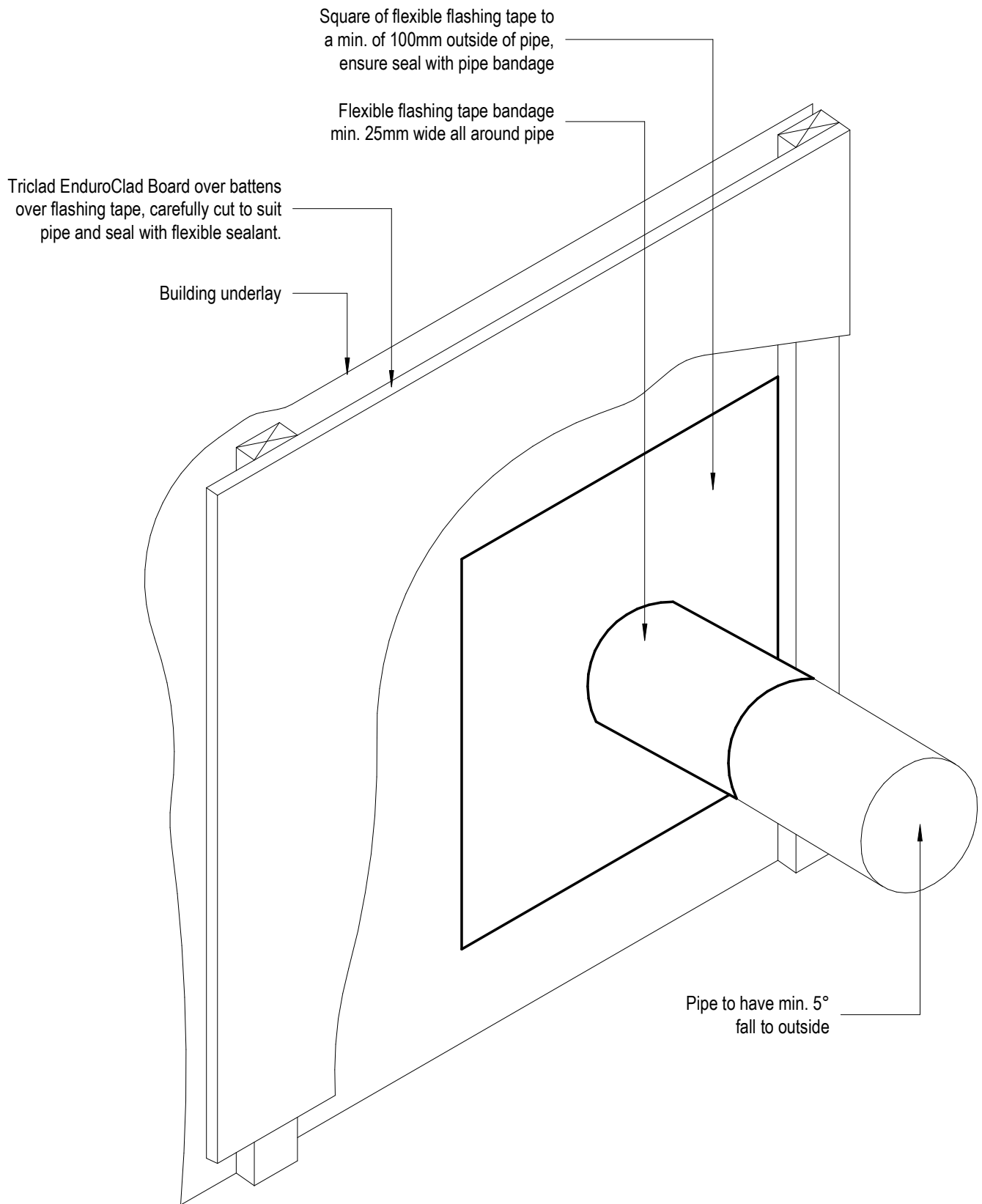

TRICLAD
CLADDING SYSTEMS

8 Quail Place
Hamilton Lake
Hamilton
New Zealand

Cavity Fix Penetration Detail

T. 0800 874 2523

E. sales@triclad.co.nz

www.triclad.co.nz

1 : 5 @ A4
Scale

Dec 2019
Date

Fig 10
Dwg

Triclad EnduroClad

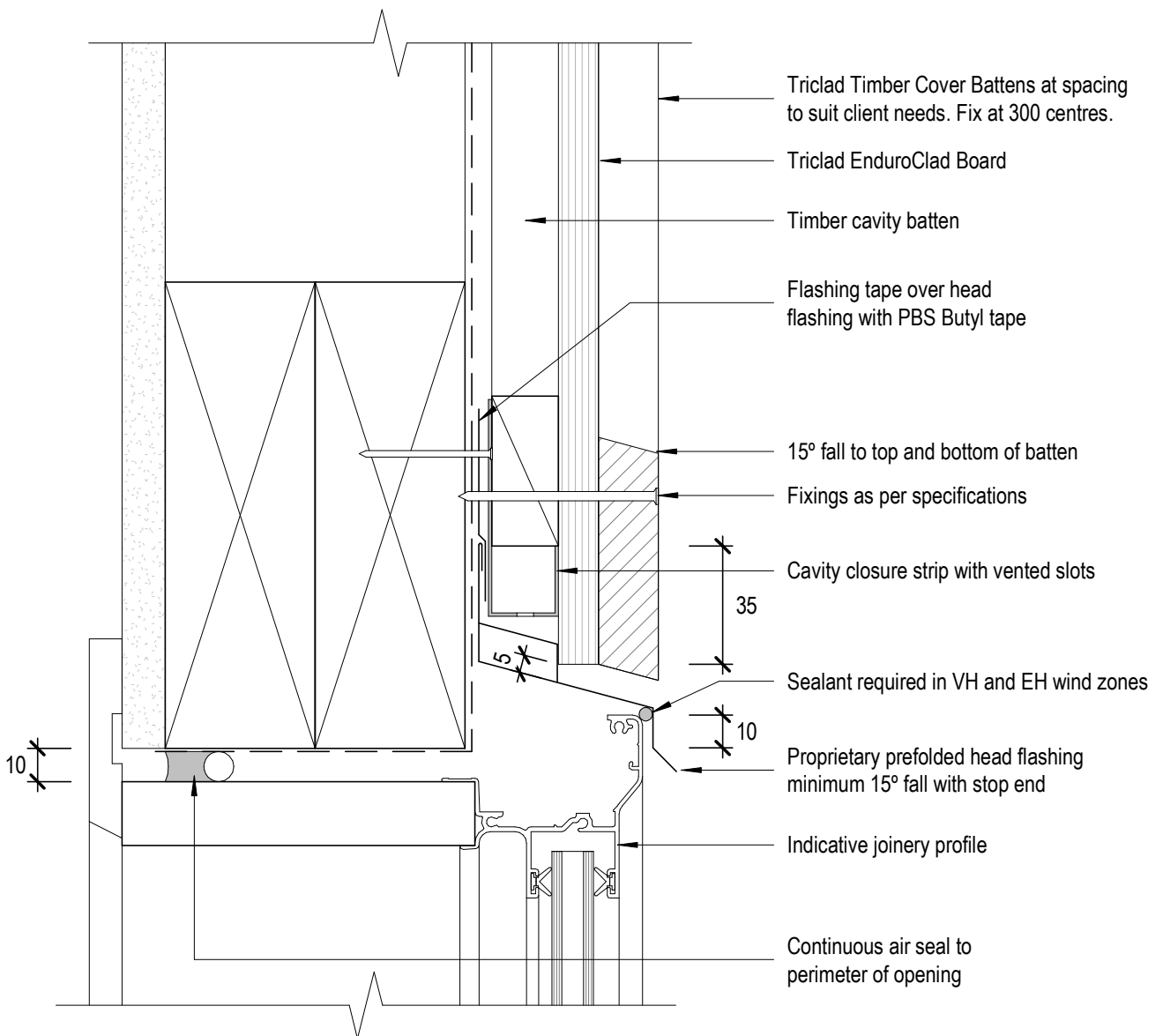
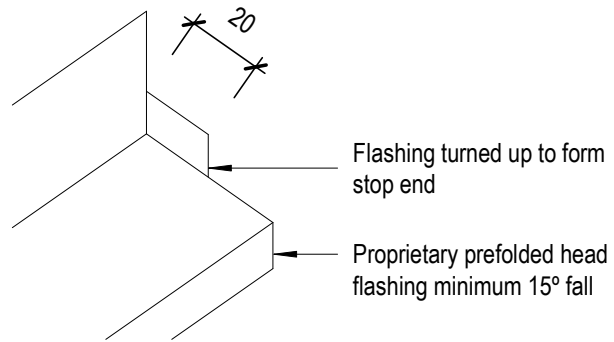

8 Quail Place
Hamilton Lake
Hamilton
New Zealand

Cavity Fix Window Head Detail-Aluminium

T. 0800 874 2523

E. sales@triclad.co.nz

www.triclad.co.nz

1 : 2 @ A4
Scale

Dec 2019
Date

Fig 11
Dwg

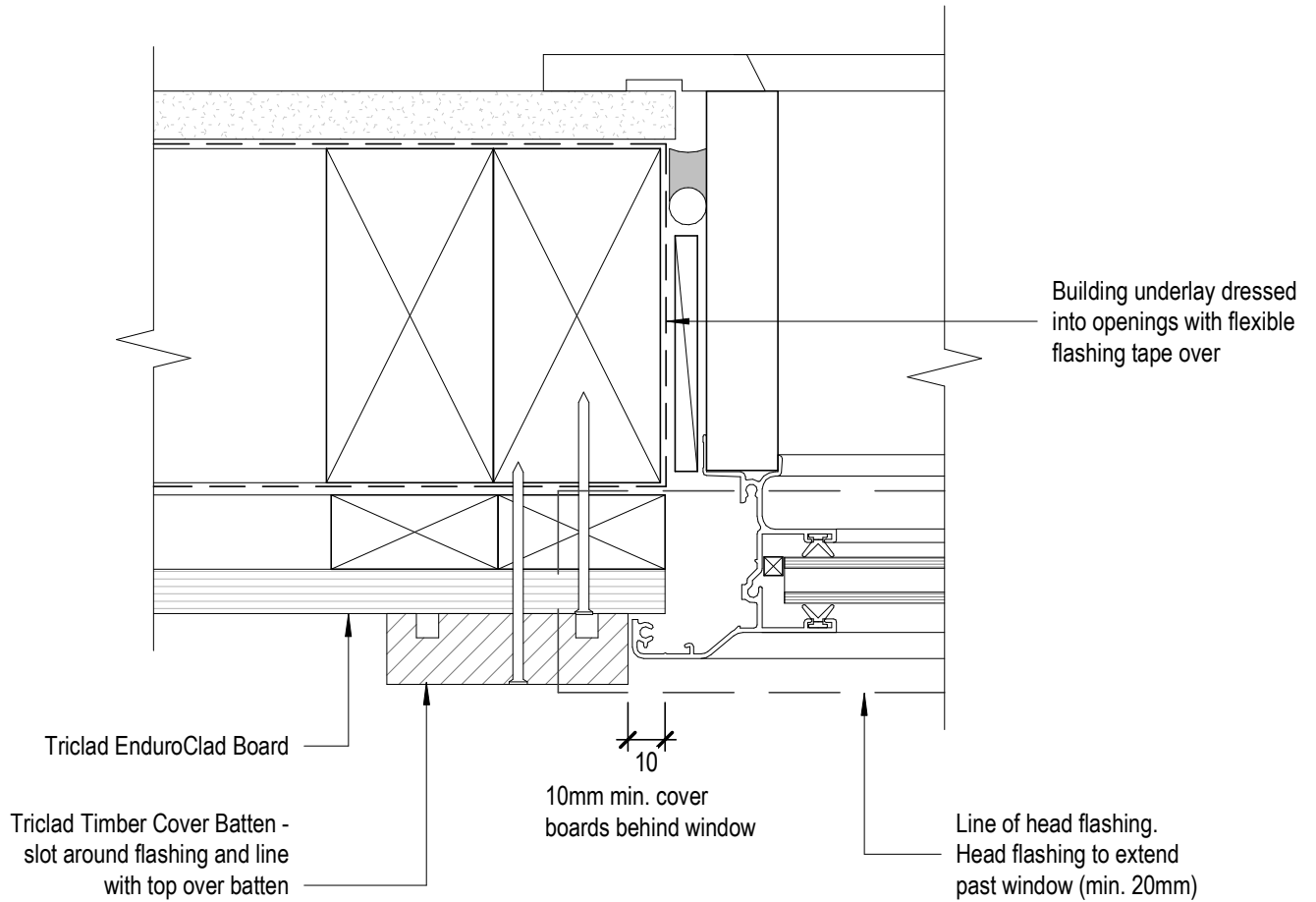

TRICLAD
CLADDING SYSTEMS

8 Quail Place
Hamilton Lake
Hamilton
New Zealand

Cavity Fix Window Jamb Detail-Aluminium

Triclad EnduroClad

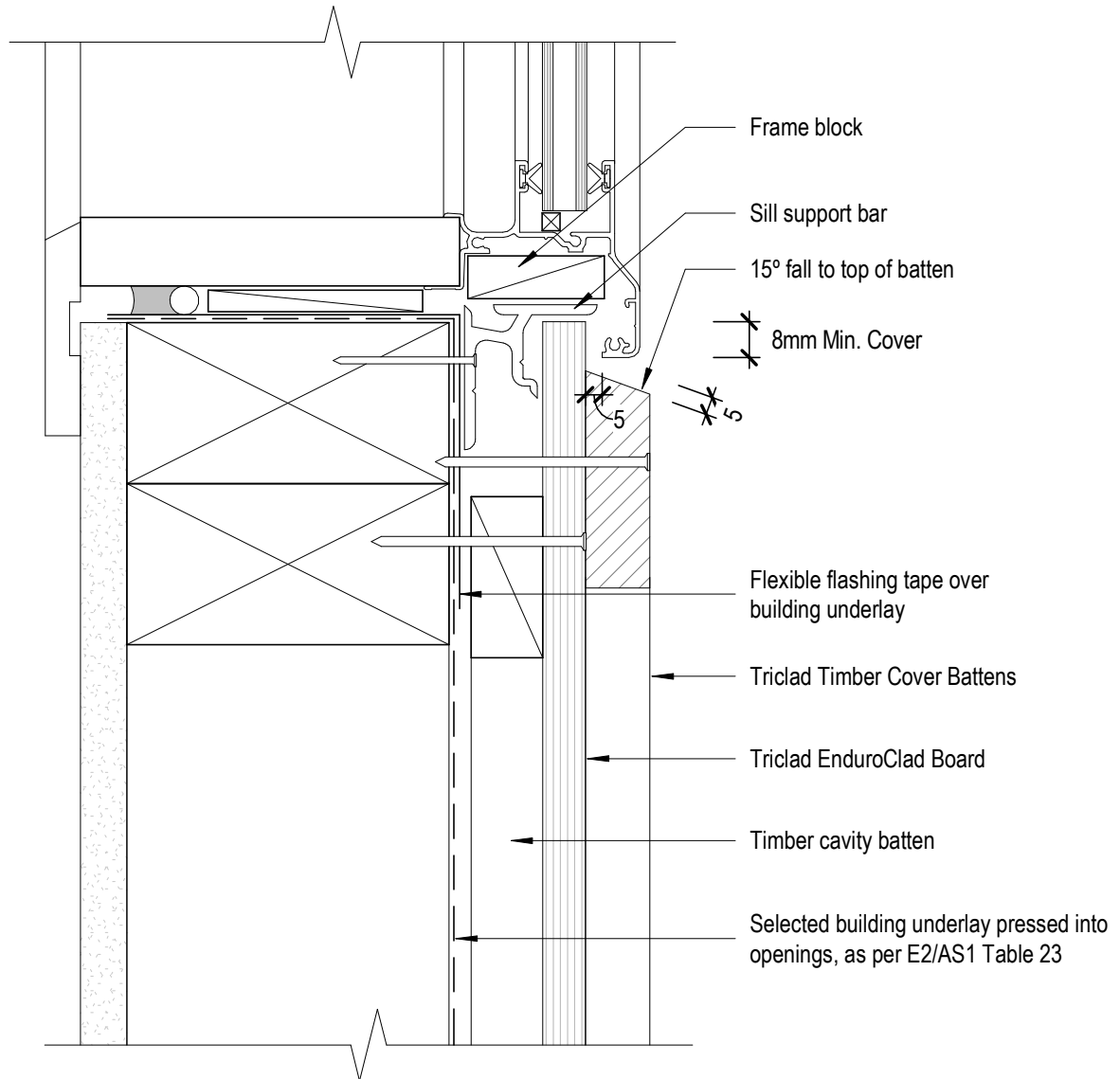

TRICLAD
CLADDING SYSTEMS

8 Quail Place
Hamilton Lake
Hamilton
New Zealand

Cavity Fix Window Sill Detail-Aluminium

T. 0800 874 2523

E. sales@triclad.co.nz

www.triclad.co.nz

1 : 2 @ A4
Scale

Dec 2019
Date

Fig 13
Dwg

Triclad EnduroClad

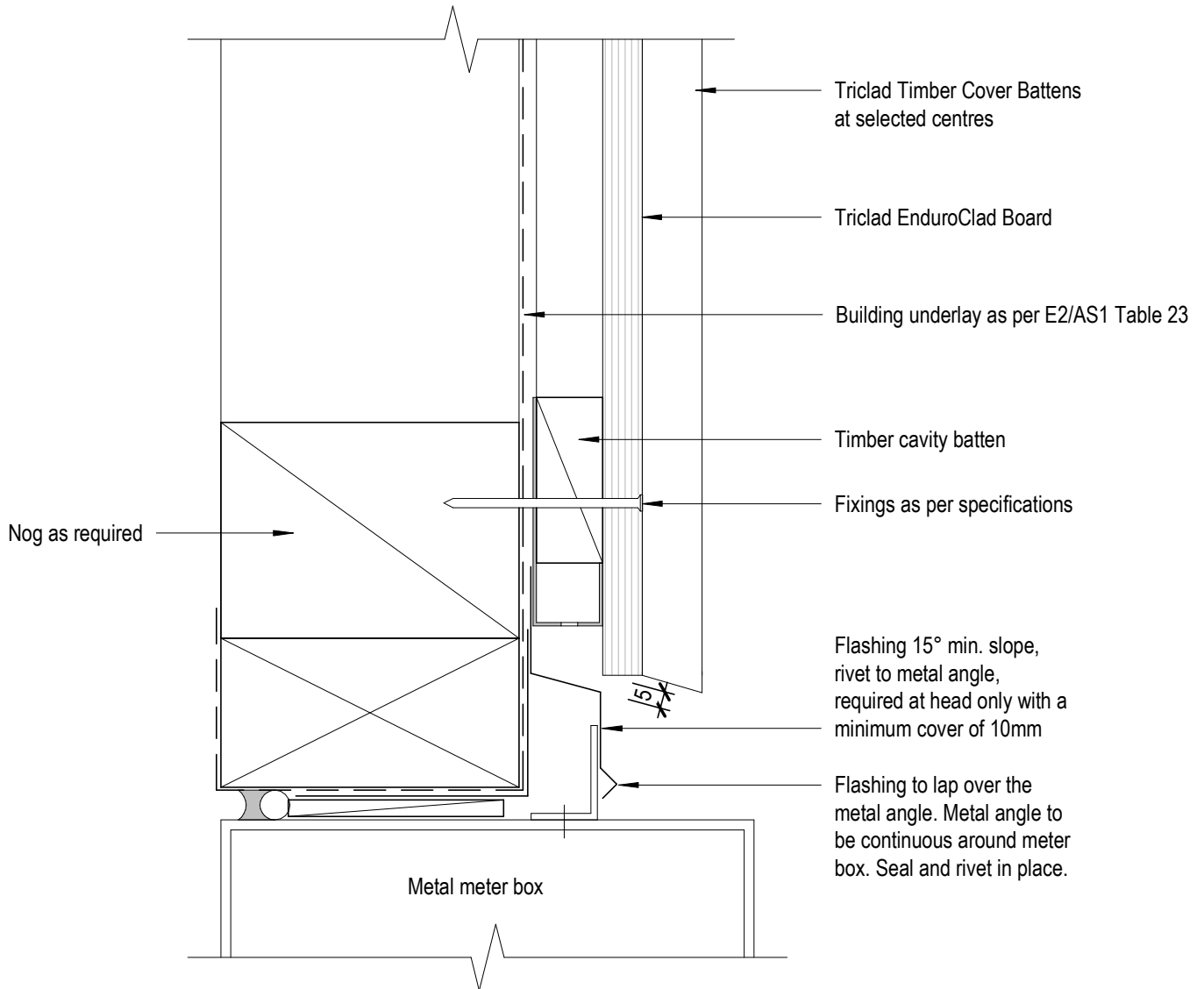

TRICLAD
CLADDING SYSTEMS

8 Quail Place
Hamilton Lake
Hamilton
New Zealand

Cavity Fix Meter Box Head

T. 0800 874 2523

E. sales@triclad.co.nz

www.triclad.co.nz

1 : 2 @ A4
Scale

Dec 2019
Date

Fig 14
Dwg

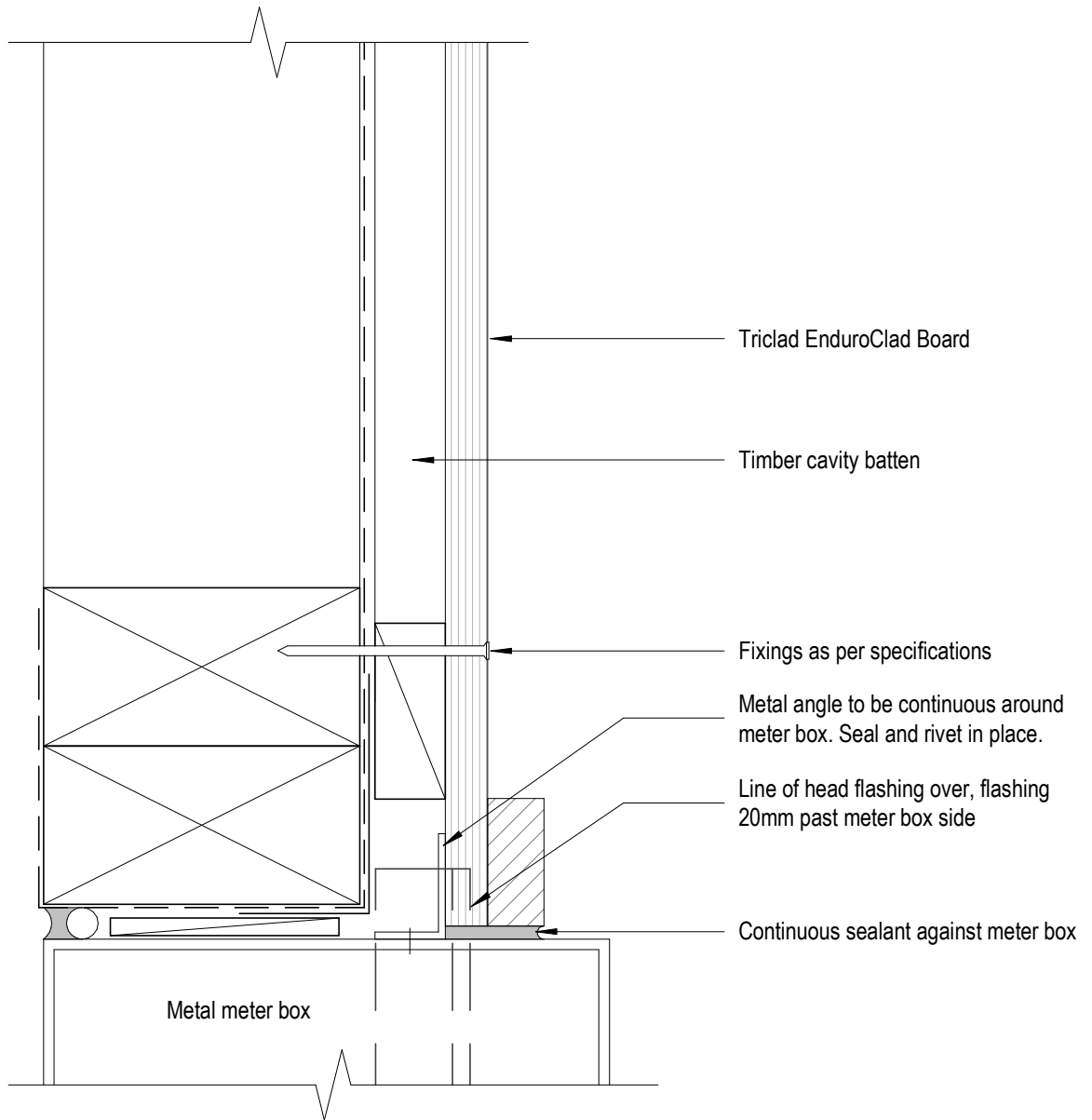

TRICLAD
CLADDING SYSTEMS

8 Quail Place
Hamilton Lake
Hamilton
New Zealand

Cavity Fix Meter Box Jamb

Triclad EnduroClad

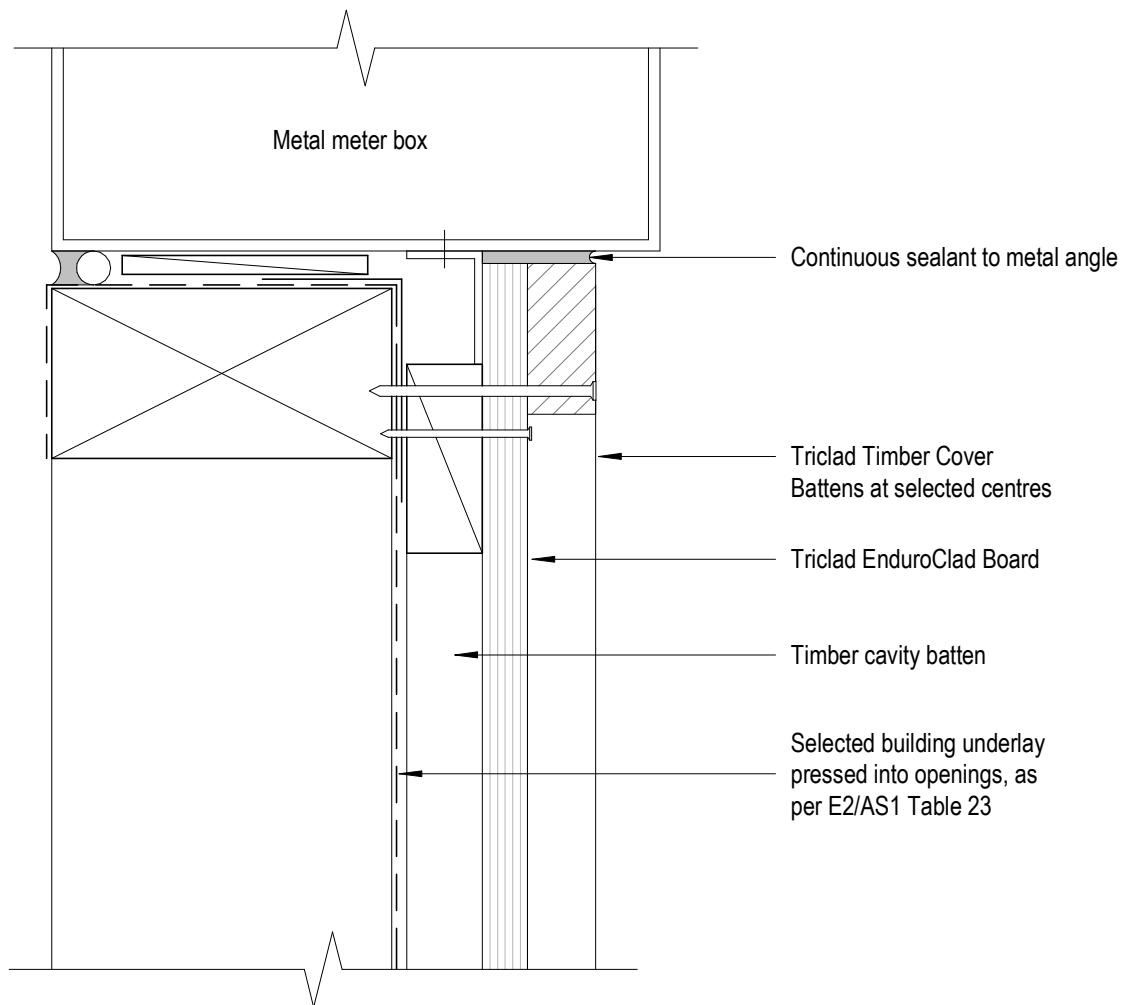

TRICLAD
CLADDING SYSTEMS

8 Quail Place
Hamilton Lake
Hamilton
New Zealand

Cavity Fix Meter Box Sill

T. 0800 874 2523

E. sales@triclad.co.nz

www.triclad.co.nz

1 : 2 @ A4
Scale

Dec 2019
Date

Fig 16
Dwg

Triclad EnduroClad

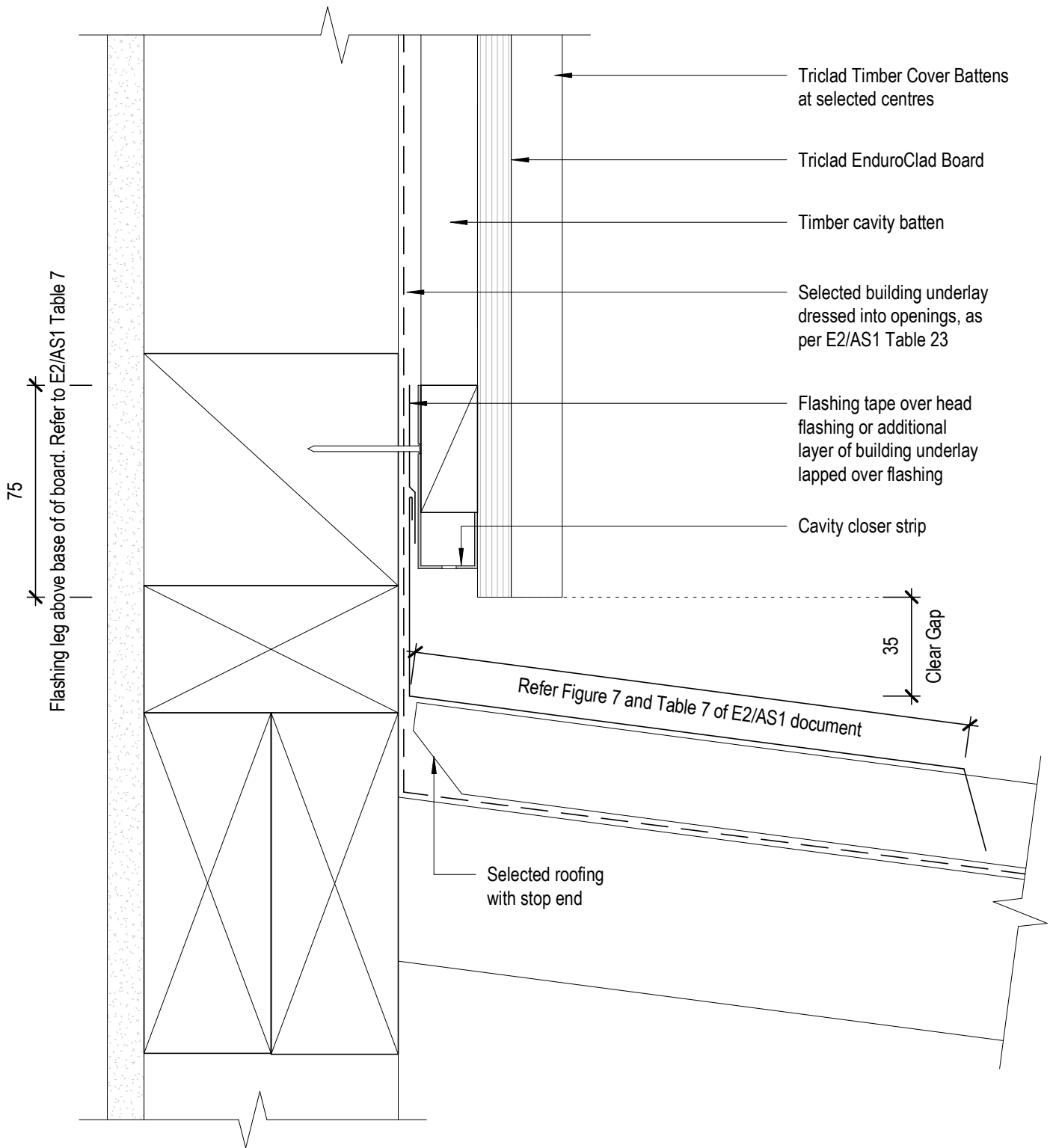

TRICLAD
CLADDING SYSTEMS

8 Quail Place
Hamilton Lake
Hamilton
New Zealand

Cavity Fix Roof/Wall Detail

T. 0800 874 2523

E. sales@triclad.co.nz

www.triclad.co.nz

1 : 2 @ A4
Scale

Dec 2019
Date

Fig 17
Dwg

Triclad EnduroClad

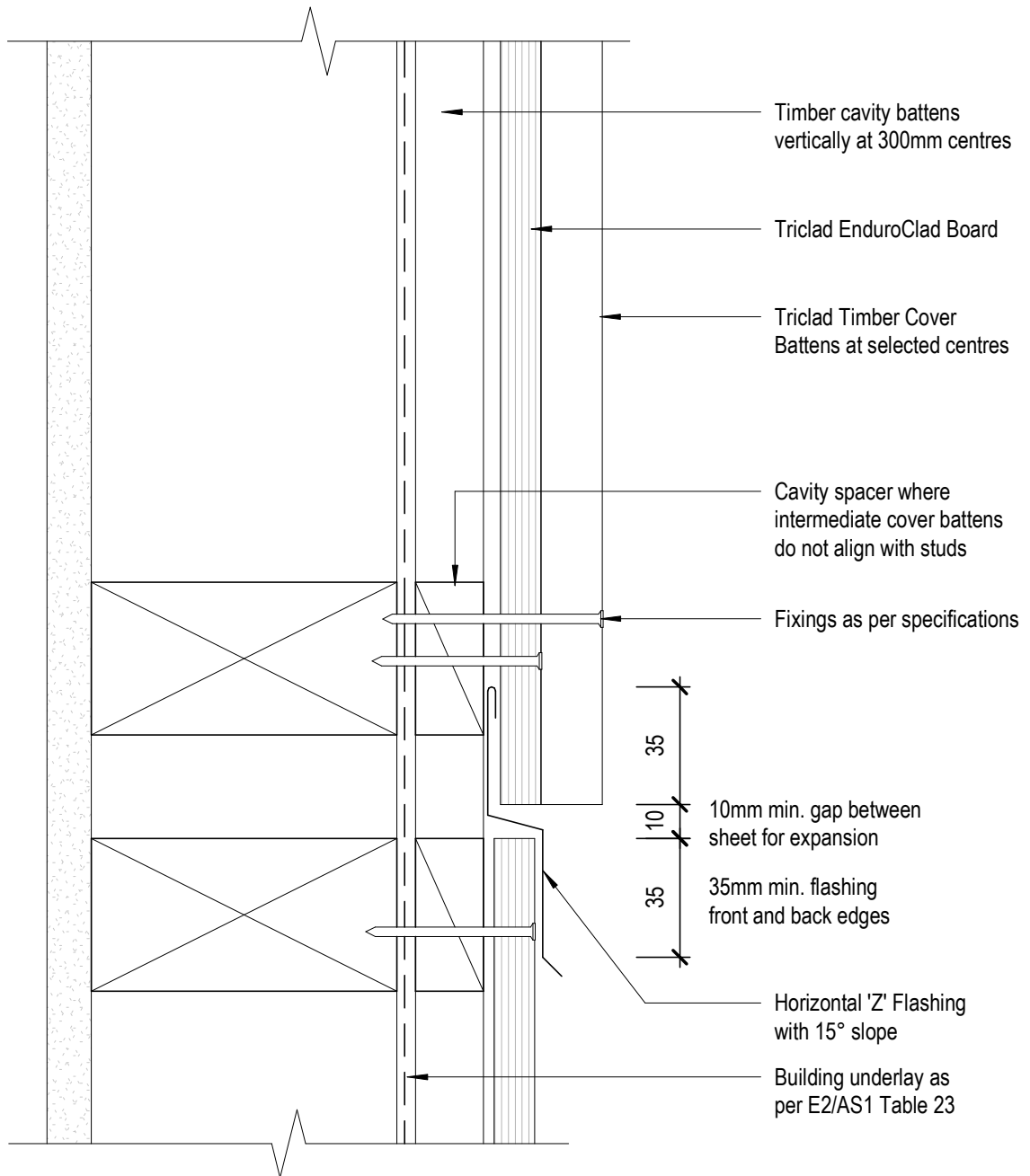

8 Quail Place
Hamilton Lake
Hamilton
New Zealand

Cavity Fix Horizontal Join Detail

T. 0800 874 2523

E. sales@triclاد.co.nz

www.triclاد.co.nz

1 : 2 @ A4
Scale

Dec 2019
Date

Fig 18
Dwg

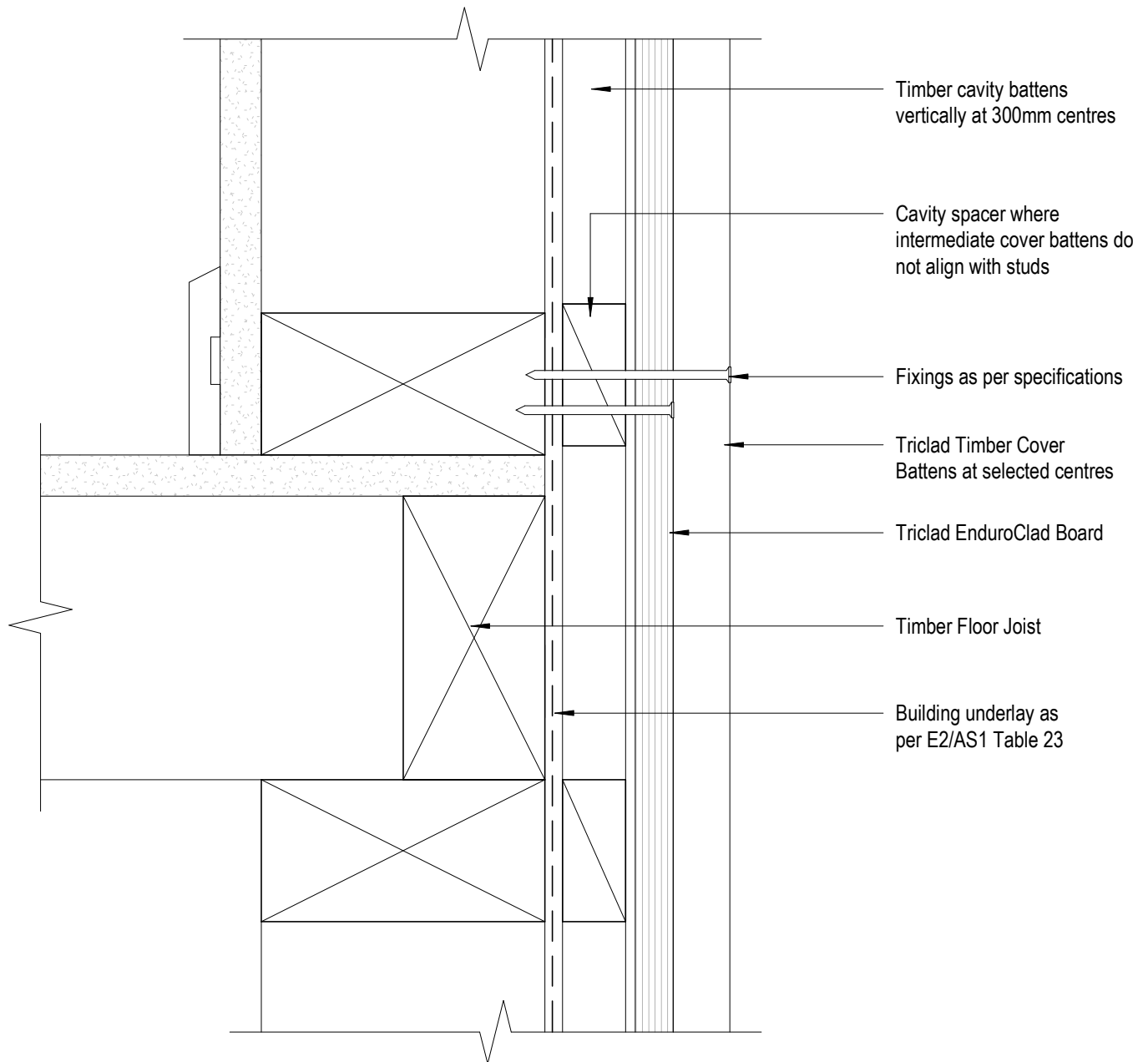

TRICLAD
CLADDING SYSTEMS

8 Quail Place
Hamilton Lake
Hamilton
New Zealand

Cavity Fix Inter-Story Detail - No Join

T. 0800 874 2523

E. sales@triclad.co.nz

www.triclad.co.nz

1 : 2 @ A4
Scale

Dec 2019
Date

Fig 18a
Dwg

Triclad EnduroClad

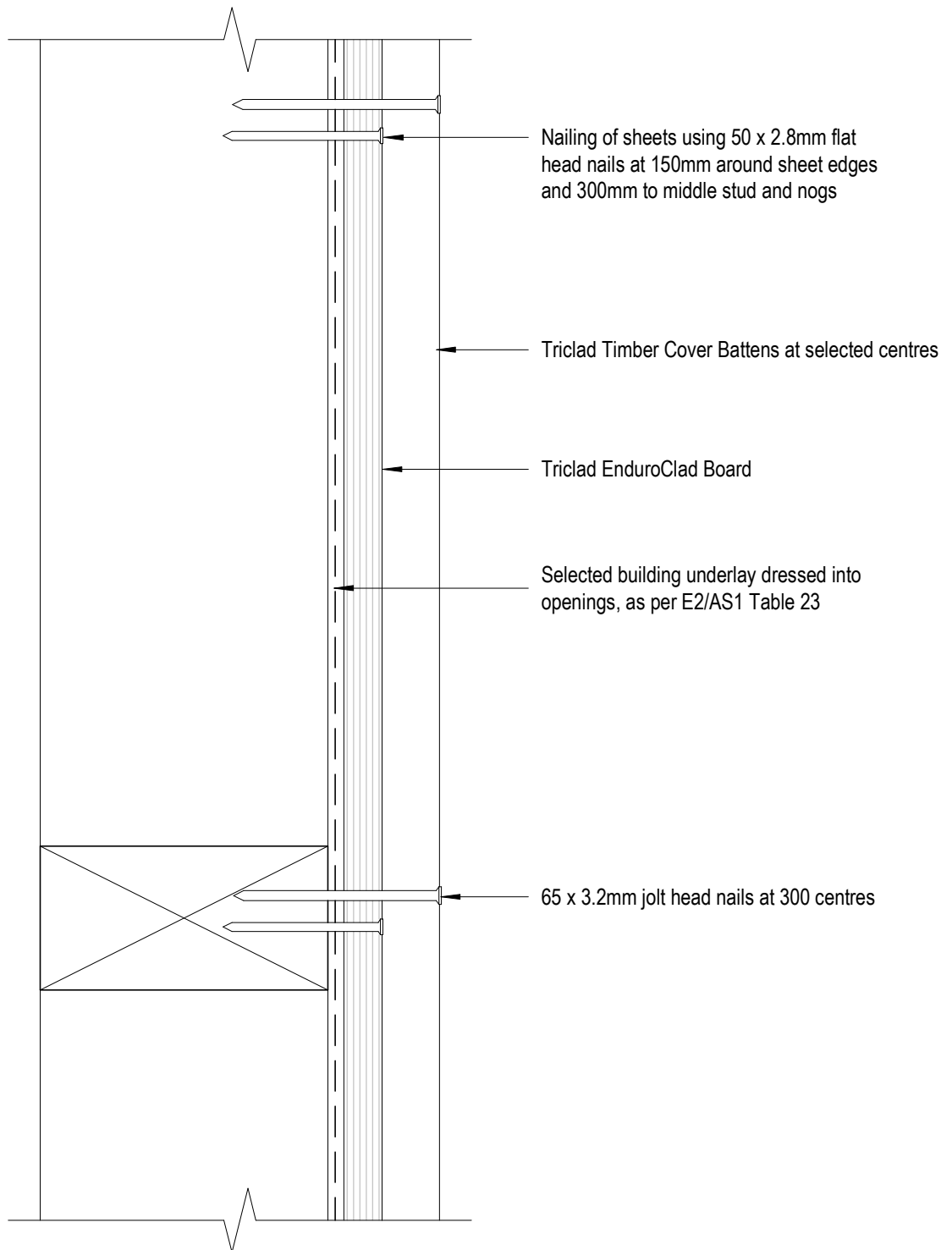

TRICLAD
CLADDING SYSTEMS

8 Quail Place
Hamilton Lake
Hamilton
New Zealand

Direct Fix Nailing Setout

T. 0800 874 2523

E. sales@triclاد.co.nz

www.triclاد.co.nz

1 : 2 @ A4
Scale

Dec 2019
Date

Fig 19
Dwg

Triclad EnduroClad

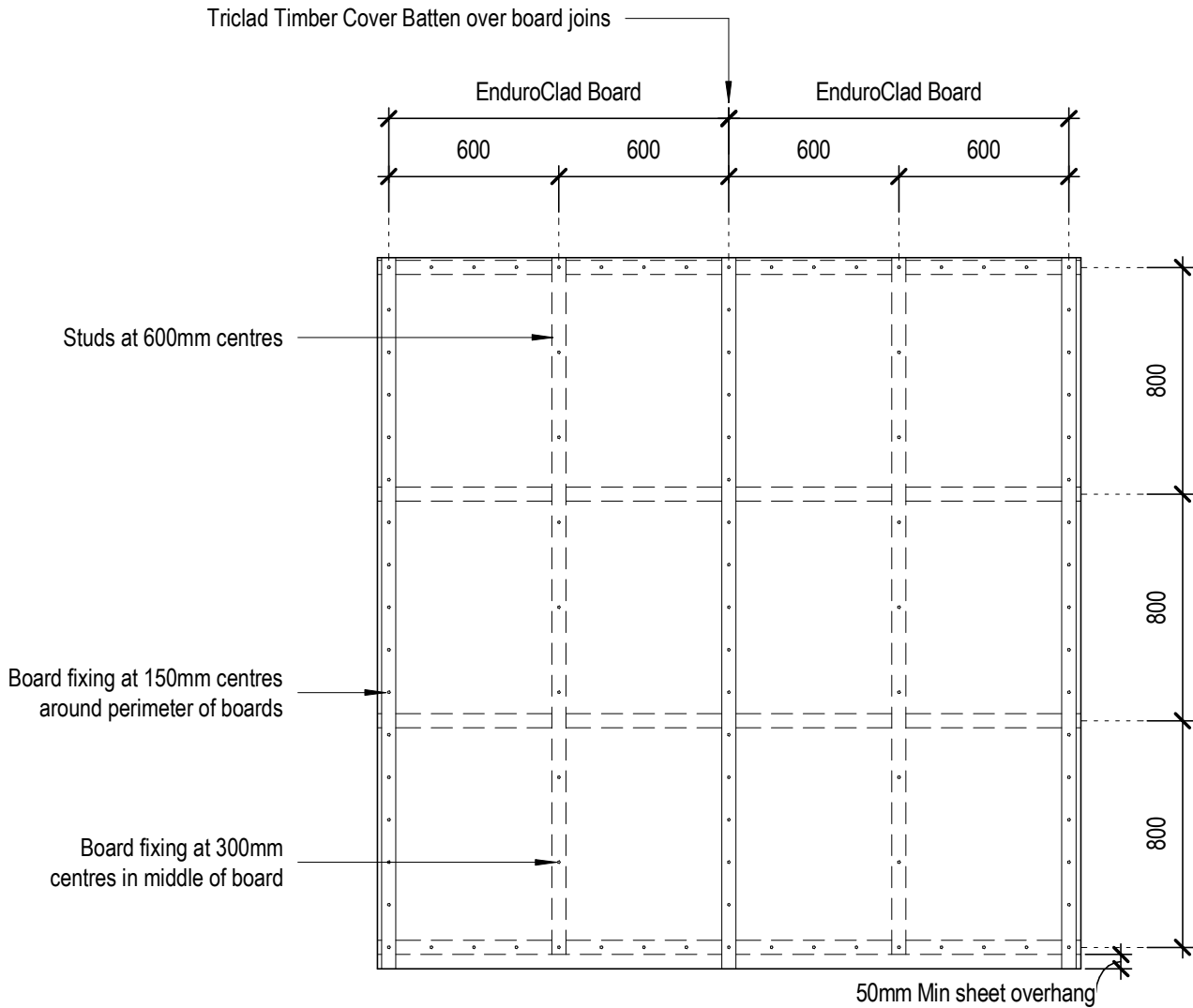

NOTE:

Where cover battens do not sit over a stud it is recommended that additional noggings are used to provide additional fixing for the decorative cover battens.



TRICLAD
CLADDING SYSTEMS

8 Quail Place
Hamilton Lake
Hamilton
New Zealand

Direct Fix Framing/Batten Setout

T. 0800 874 2523

E. sales@triclad.co.nz

www.triclad.co.nz

1 : 25 @ A4
Scale

Dec 2019
Date

Fig 20
Dwg

Triclad EnduroClad

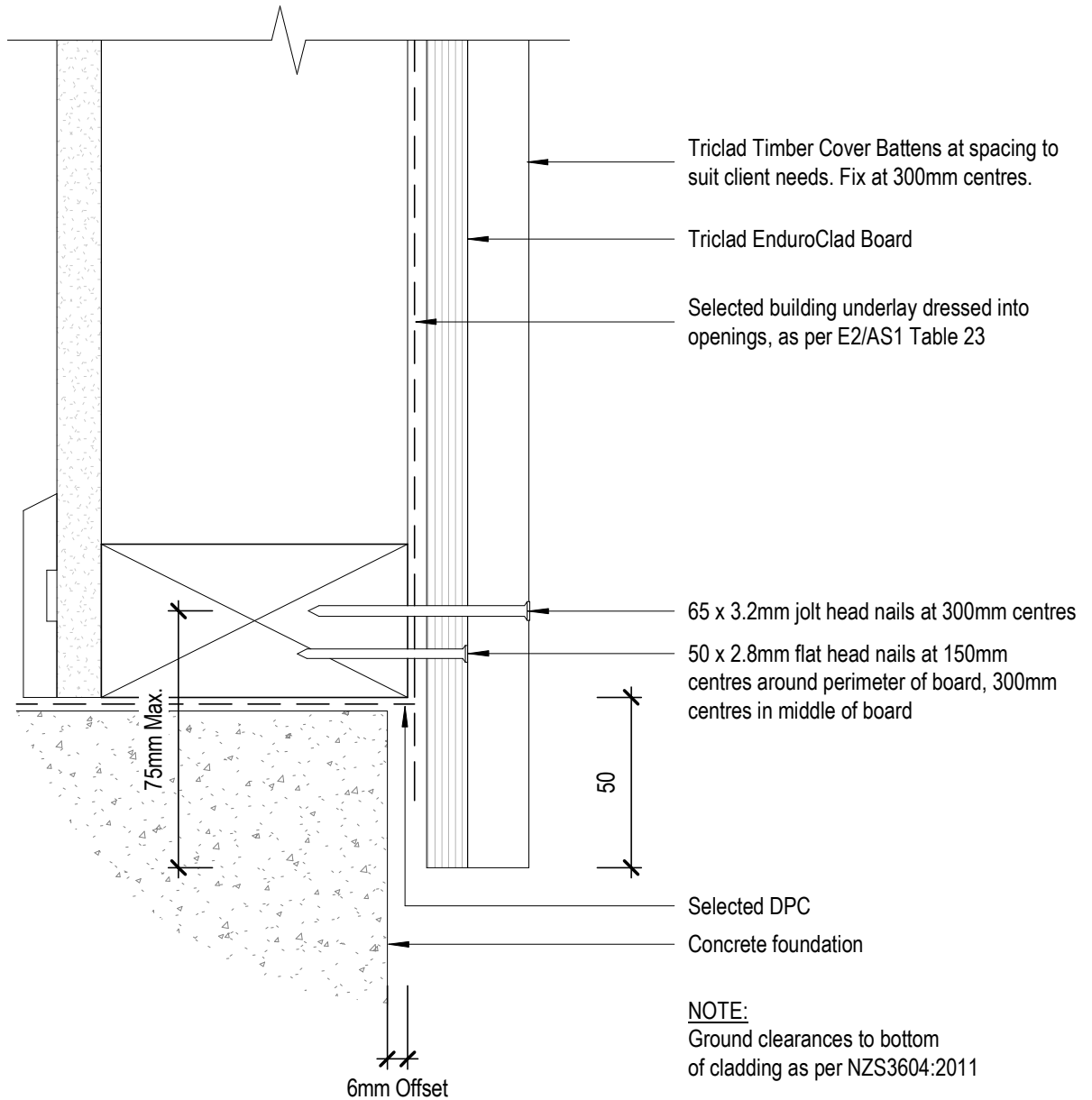

TRICLAD
CLADDING SYSTEMS

8 Quail Place
Hamilton Lake
Hamilton
New Zealand

Direct Fix Base Detail-Concrete Floor

T. 0800 874 2523

E. sales@triclad.co.nz

www.triclad.co.nz

1 : 2 @ A4
Scale

Dec 2019
Date

Fig 21
Dwg

Triclad EnduroClad

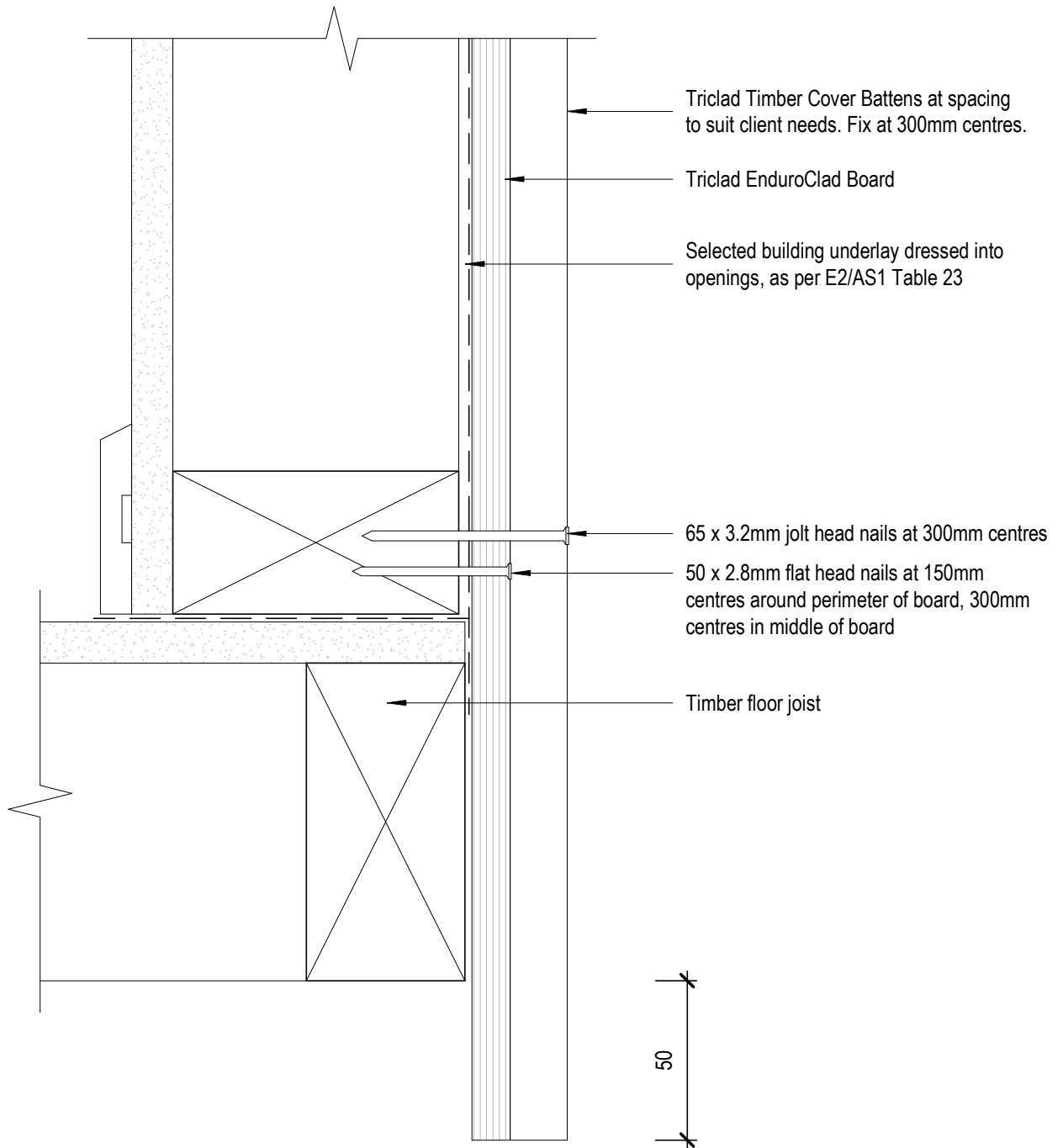

TRICLAD
CLADDING SYSTEMS

8 Quail Place
Hamilton Lake
Hamilton
New Zealand

Direct Fix Base Detail-Timber Floor

T. 0800 874 2523

E. sales@triclad.co.nz

www.triclad.co.nz

1 : 2 @ A4
Scale

Dec 2019
Date

Fig 22
Dwg

Triclad EnduroClad

**Non-Corner Flashing
Optional Detail:**

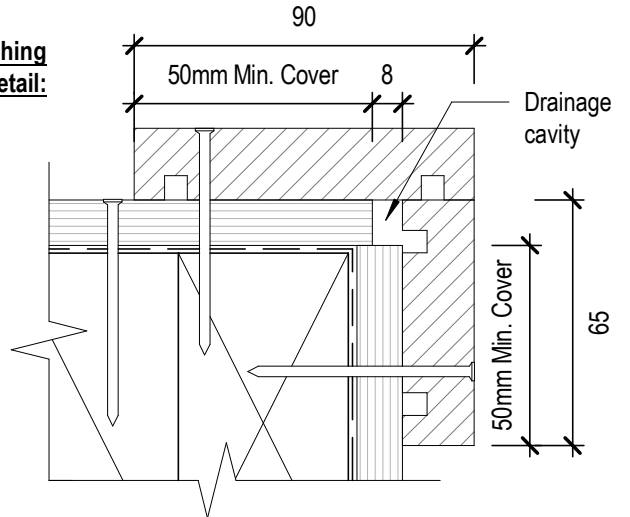

Timber facing boards, rip to suit cover
65 x 3.2mm jolt head nails at 300 centres

Blocking where required

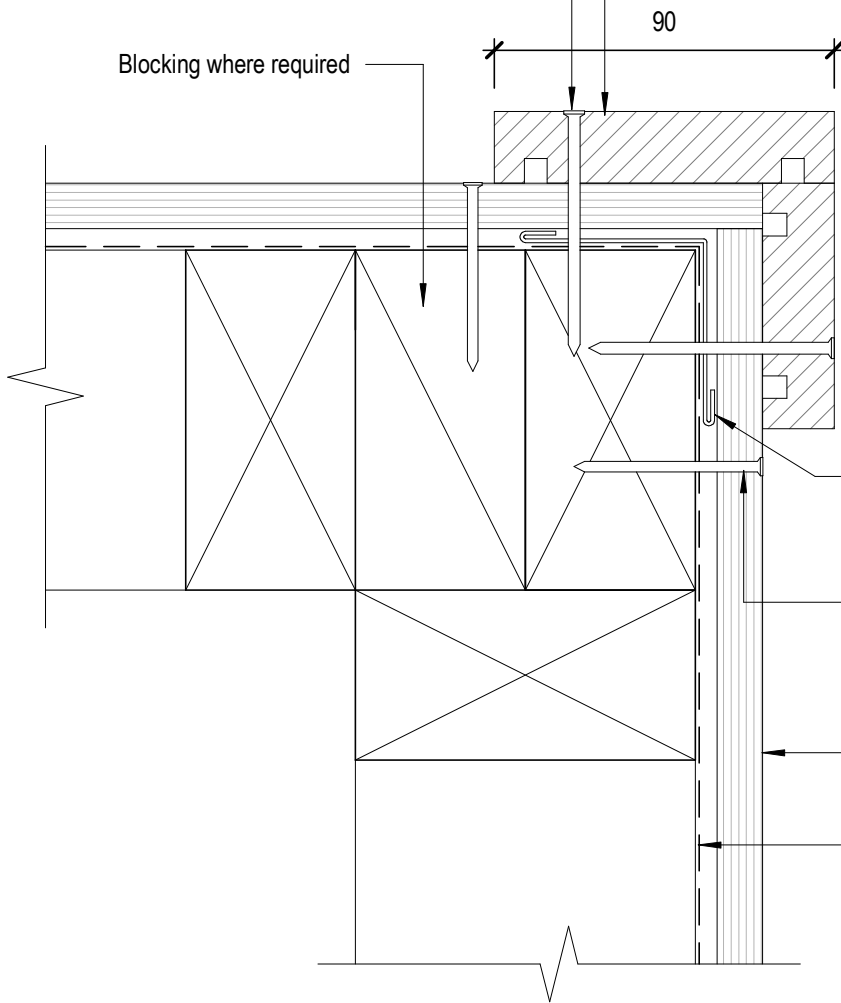

Minimum 50x50mm external corner flashing hem edge folds compatibility to comply with NZBC E2/AS1

50 x 2.8mm flat head nails at 150mm centres around perimeter of board, 300mm centres in middle of board

Triclad EnduroClad Board

Building underlay continuous around corner as per E2/AS1 Table 23



8 Quail Place
Hamilton Lake
Hamilton
New Zealand

Direct Fix External Corner-Boxed

T. 0800 874 2523

E. sales@triclad.co.nz

www.triclad.co.nz

1 : 2 @ A4
Scale

Dec 2019
Date

Fig 23
Dwg

Triclad EnduroClad

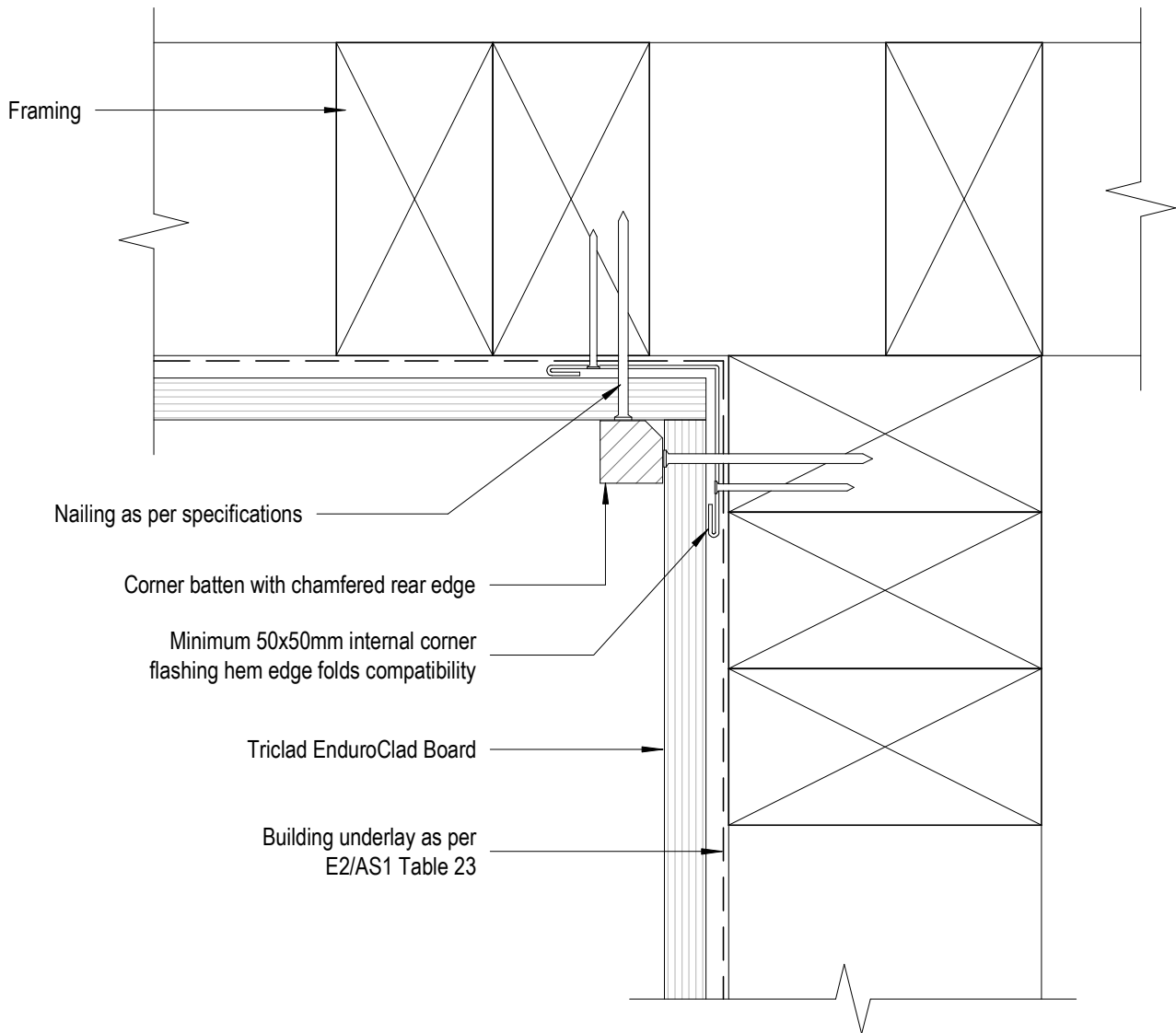

TRICLAD
CLADDING SYSTEMS

8 Quail Place
Hamilton Lake
Hamilton
New Zealand

**Direct Fix
Internal Corner**

T. 0800 874 2523

E. sales@triclad.co.nz

www.triclad.co.nz

1 : 2 @ A4
Scale

Dec 2019
Date

Fig 24
Dwg

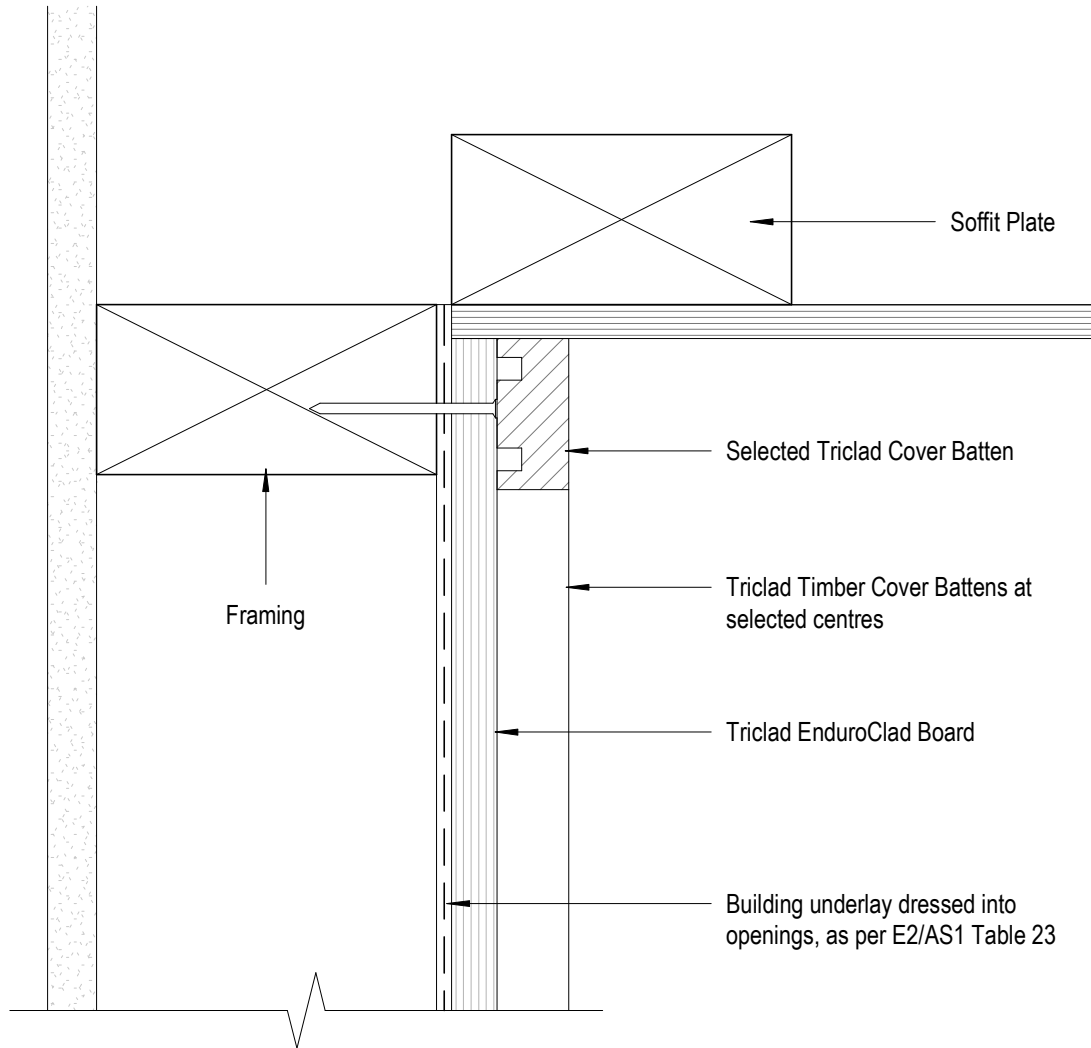

TRICLAD
CLADDING SYSTEMS

8 Quail Place
Hamilton Lake
Hamilton
New Zealand

**Direct Fix
Soffit Detail**

Triclad EnduroClad

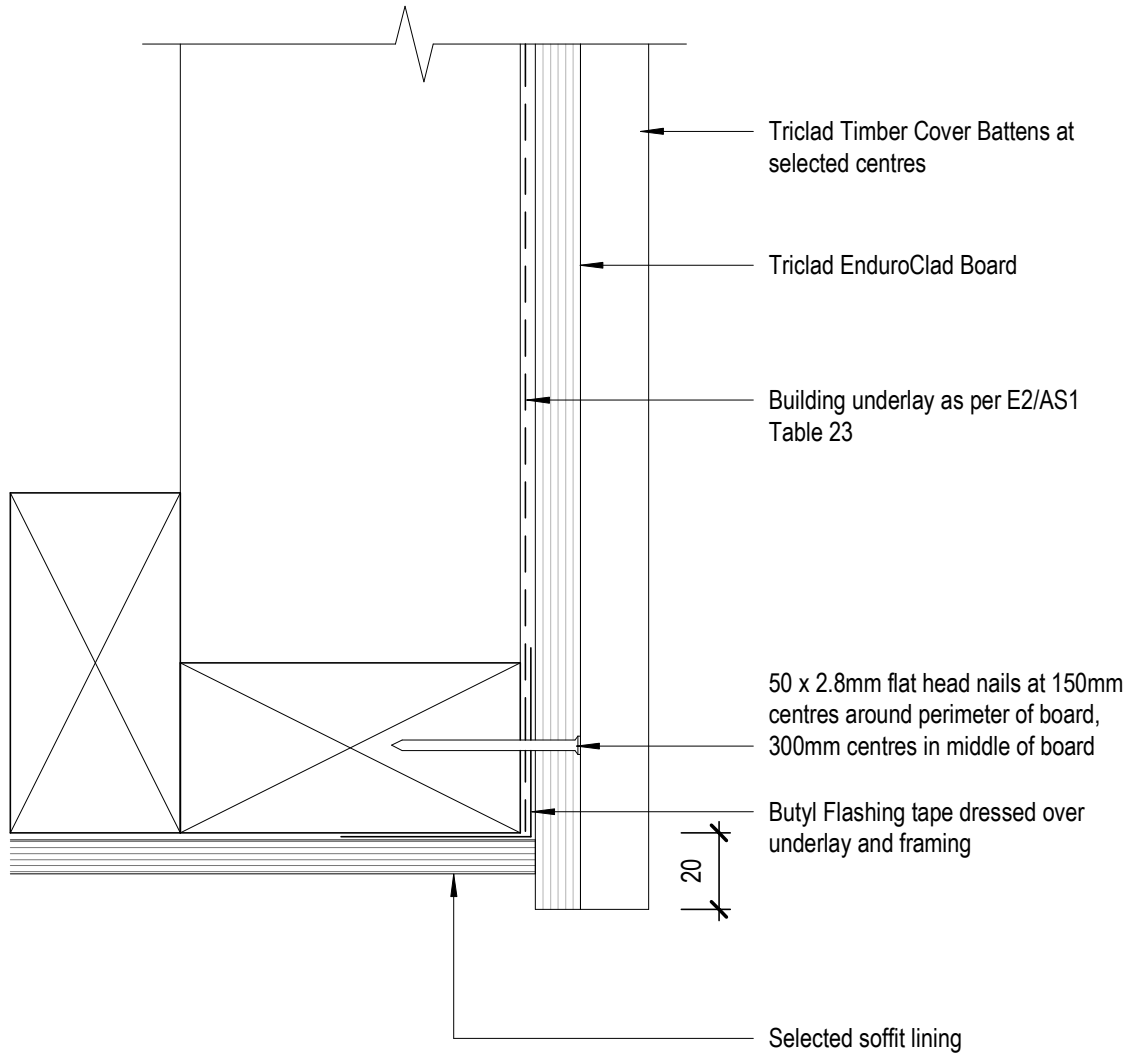

TRICLAD
CLADDING SYSTEMS

8 Quail Place
Hamilton Lake
Hamilton
New Zealand

Direct Fix Soffit/Beam Detail

T. 0800 874 2523

E. sales@triclad.co.nz

www.triclad.co.nz

1 : 2 @ A4
Scale

Dec 2019
Date

Fig 26
Dwg

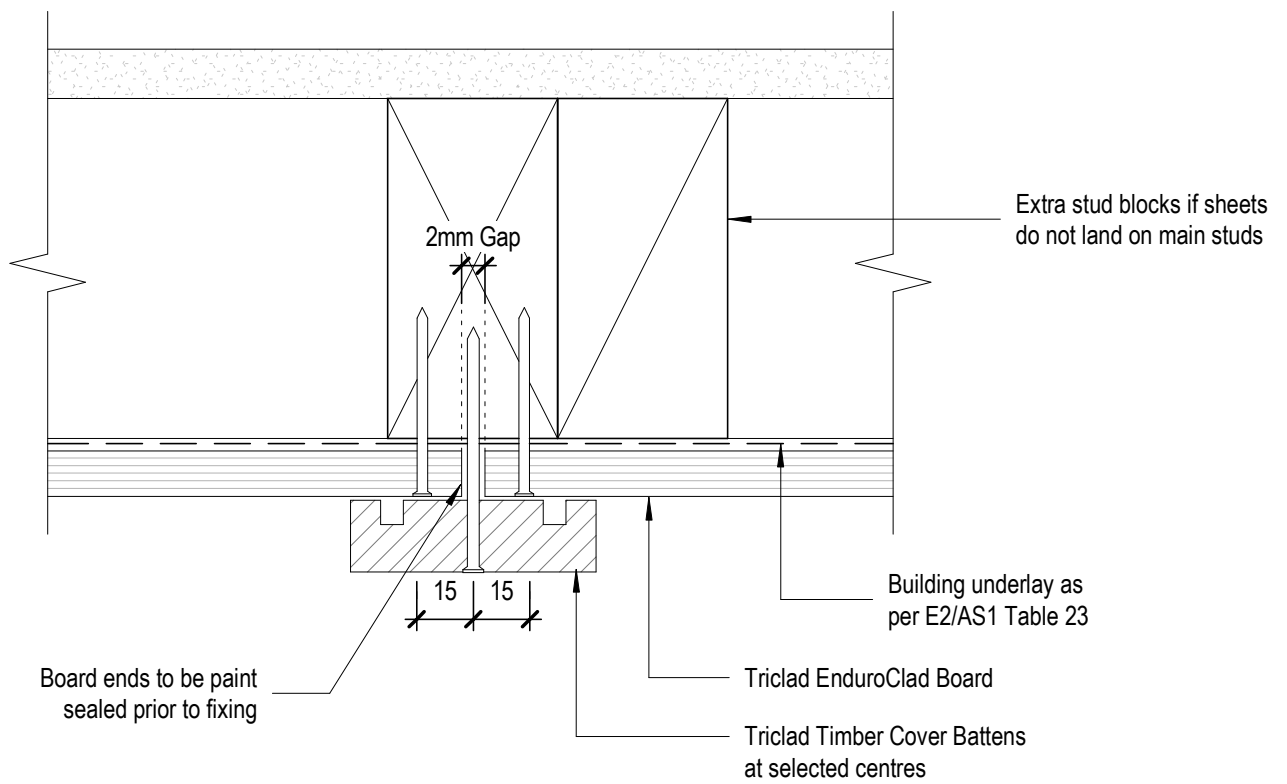

TRICLAD
CLADDING SYSTEMS

8 Quail Place
Hamilton Lake
Hamilton
New Zealand

Direct Fix Board Joint Detail

Triclad EnduroClad

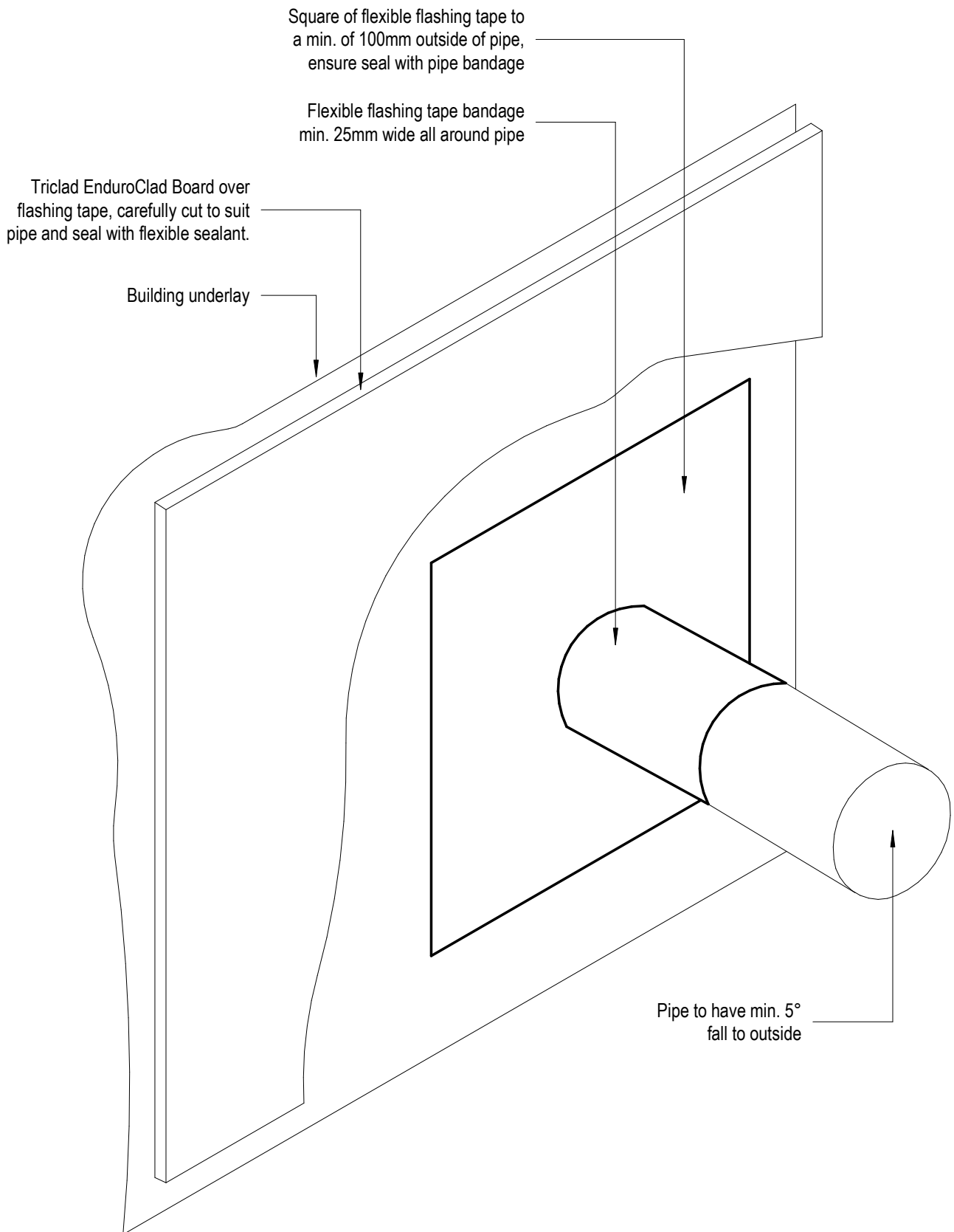

TRICLAD
CLADDING SYSTEMS

8 Quail Place
Hamilton Lake
Hamilton
New Zealand

Direct Fix Penetration Detail

T. 0800 874 2523

E. sales@triclad.co.nz

www.triclad.co.nz

1 : 5 @ A4
Scale

Dec 2019
Date

Fig 28
Dwg

Triclad EnduroClad

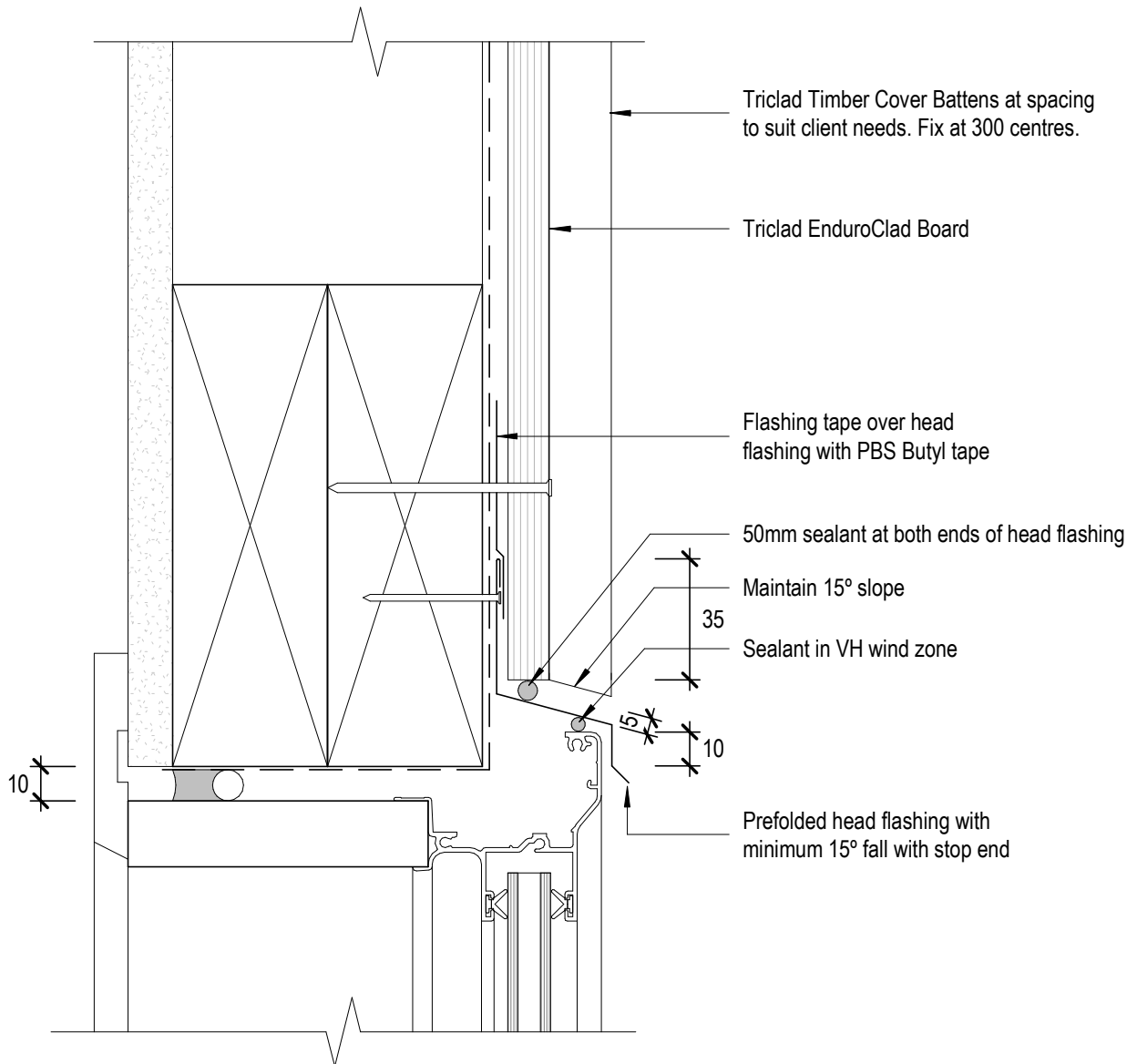

TRICLAD
CLADDING SYSTEMS

8 Quail Place
Hamilton Lake
Hamilton
New Zealand

Direct Fix Window Head Detail-Aluminium

T. 0800 874 2523

E. sales@triclad.co.nz

www.triclad.co.nz

1 : 2 @ A4
Scale

Dec 2019
Date

Fig 29
Dwg

Triclad EnduroClad

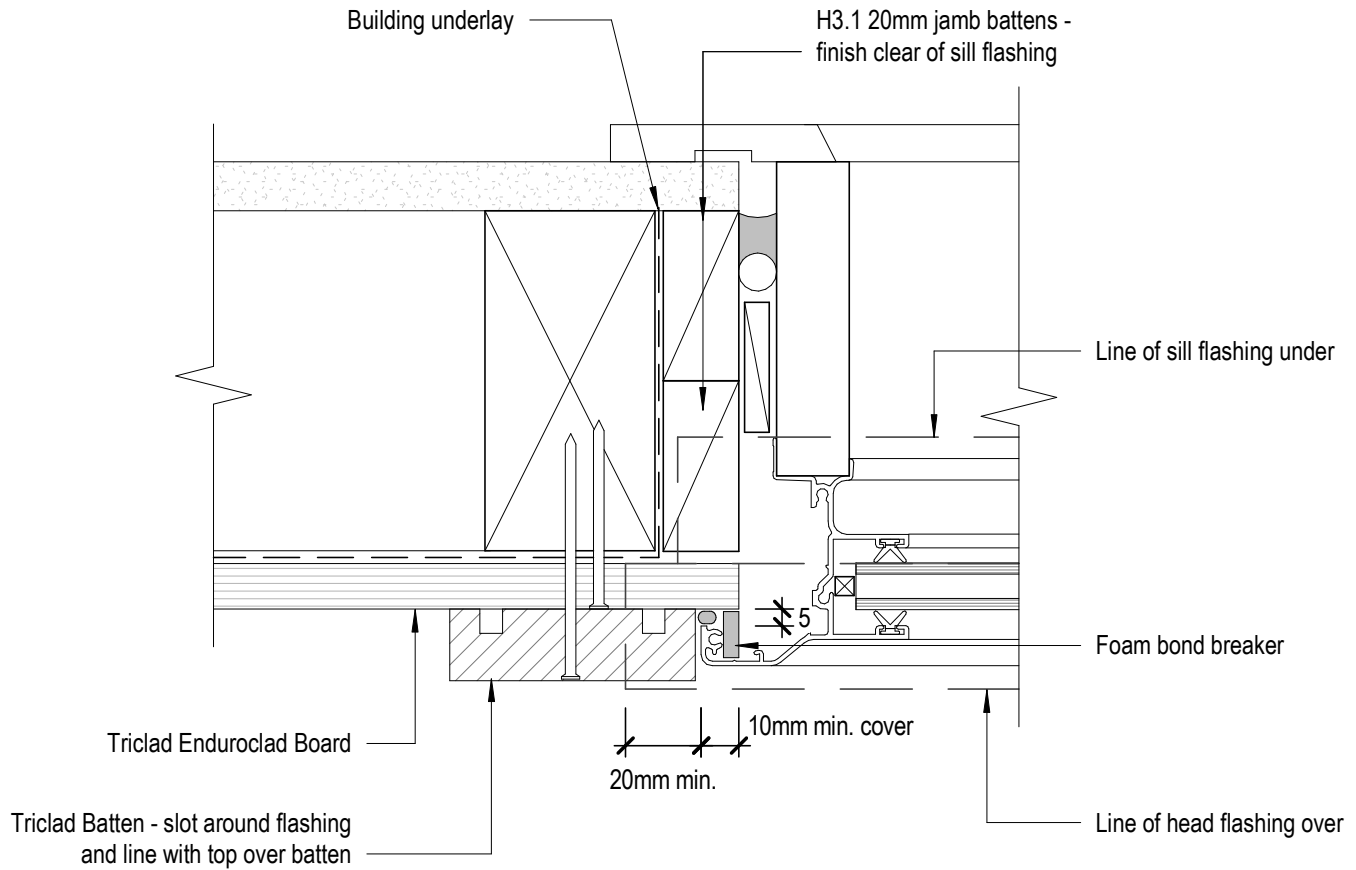

TRICLAD
CLADDING SYSTEMS

8 Quail Place
Hamilton Lake
Hamilton
New Zealand

Direct Fix
Window Jamb Detail-Aluminium

T. 0800 874 2523

E. sales@triclad.co.nz

www.triclad.co.nz

1 : 2 @ A4
Scale

Dec 2019
Date

Fig 30
Dwg

Triclad EnduroClad

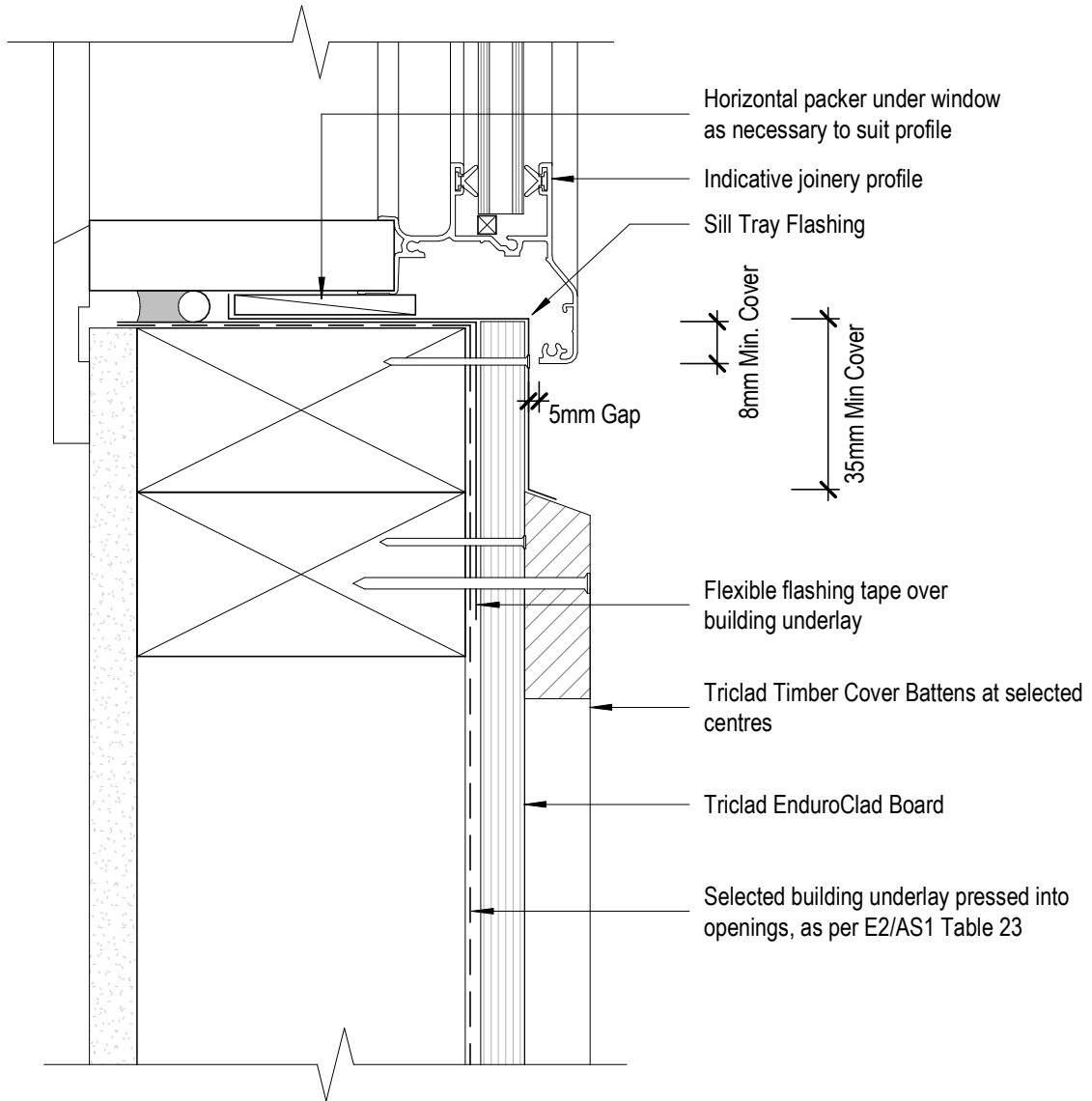

TRICLAD
CLADDING SYSTEMS

8 Quail Place
Hamilton Lake
Hamilton
New Zealand

Direct Fix Window Sill Detail-Aluminium

T. 0800 874 2523

E. sales@triclad.co.nz

www.triclad.co.nz

1 : 2 @ A4
Scale

Dec 2019
Date

Fig 31
Dwg

Triclad EnduroClad

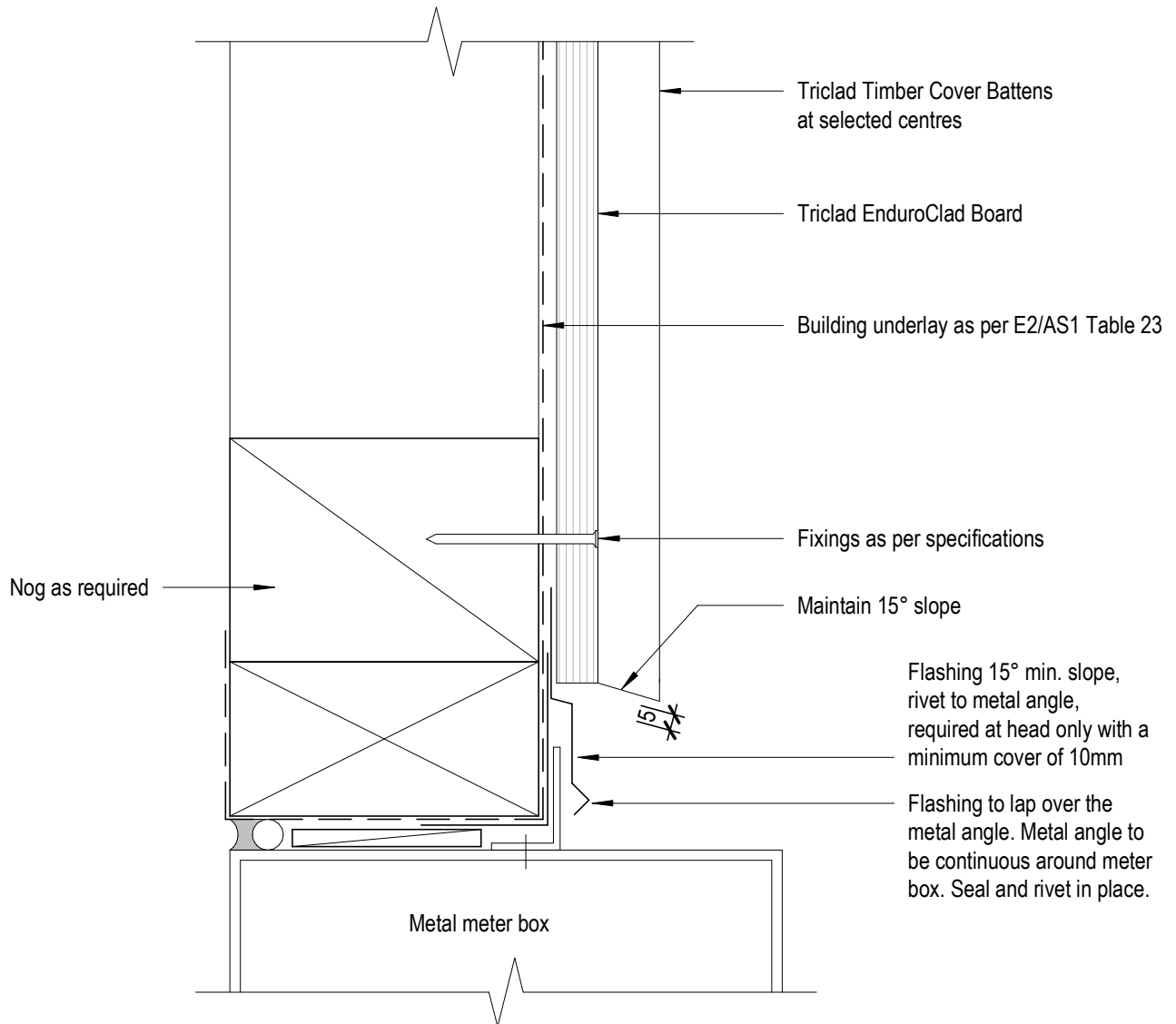

TRICLAD
CLADDING SYSTEMS

8 Quail Place
Hamilton Lake
Hamilton
New Zealand

Direct Fix Meter Box Head

T. 0800 874 2523

E. sales@triclad.co.nz

www.triclad.co.nz

1 : 2 @ A4
Scale

Dec 2019
Date

Fig 32
Dwg

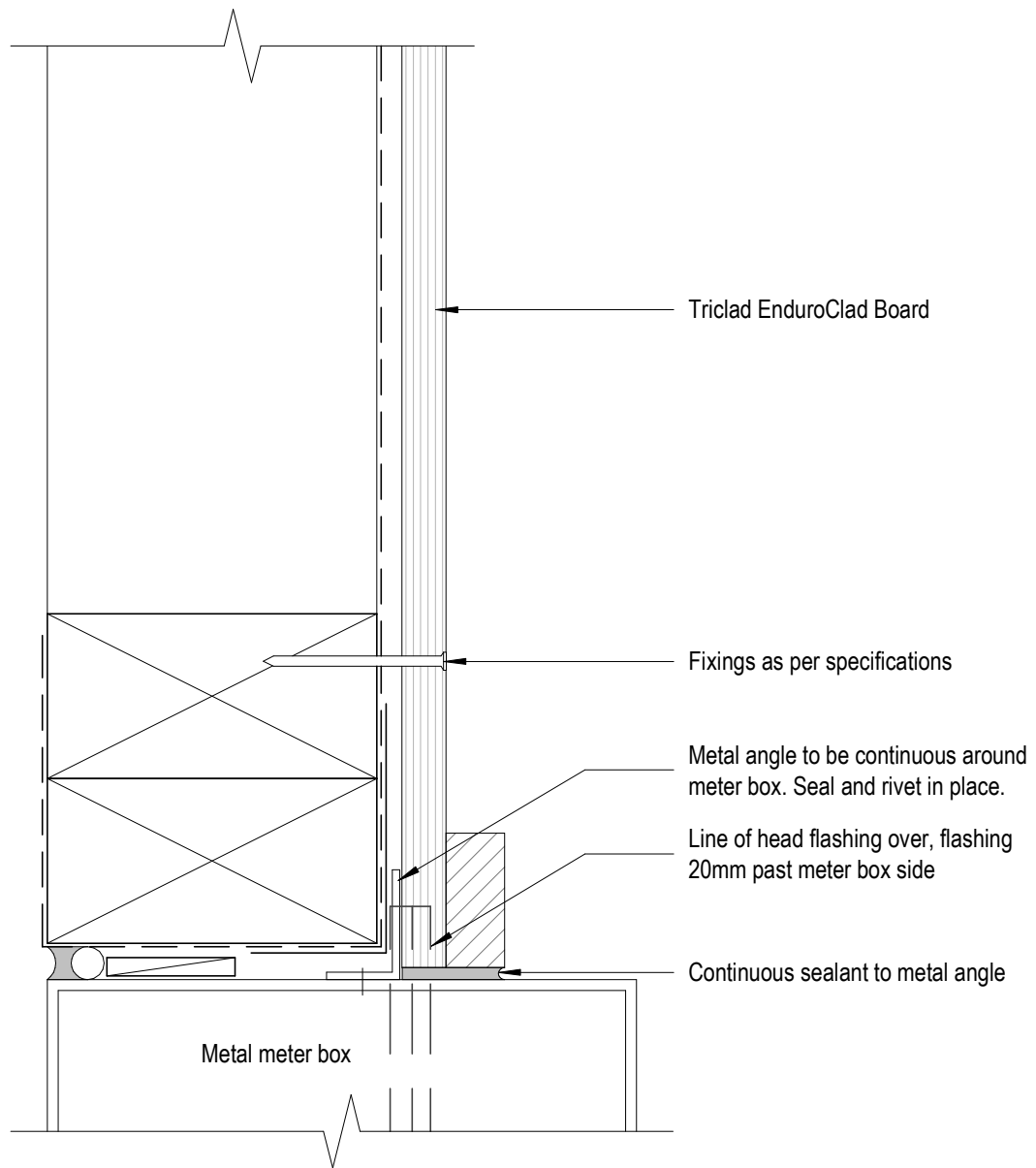

TRICLAD
CLADDING SYSTEMS

8 Quail Place
Hamilton Lake
Hamilton
New Zealand

Direct Fix Meter Box Jamb

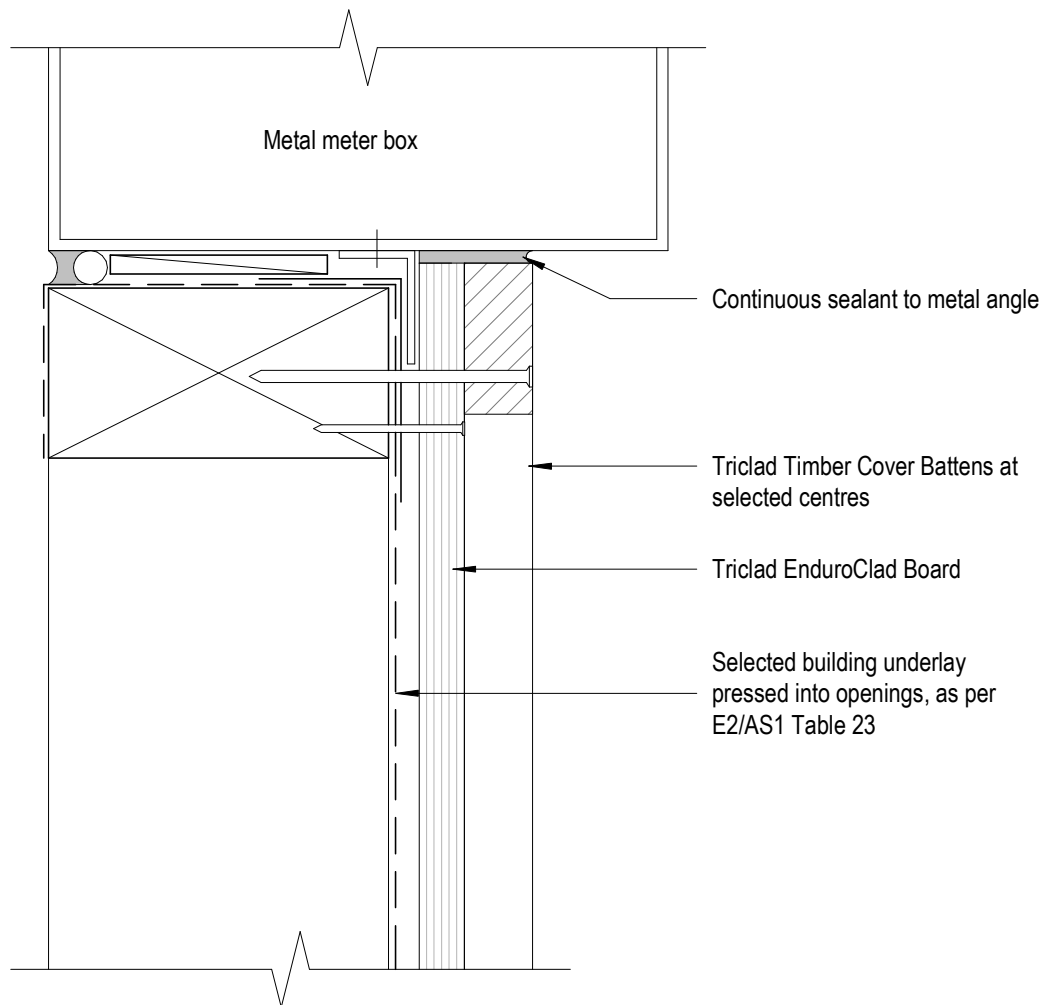

TRICLAD
CLADDING SYSTEMS

8 Quail Place
Hamilton Lake
Hamilton
New Zealand

Direct Fix Meter Box Sill

Triclad EnduroClad

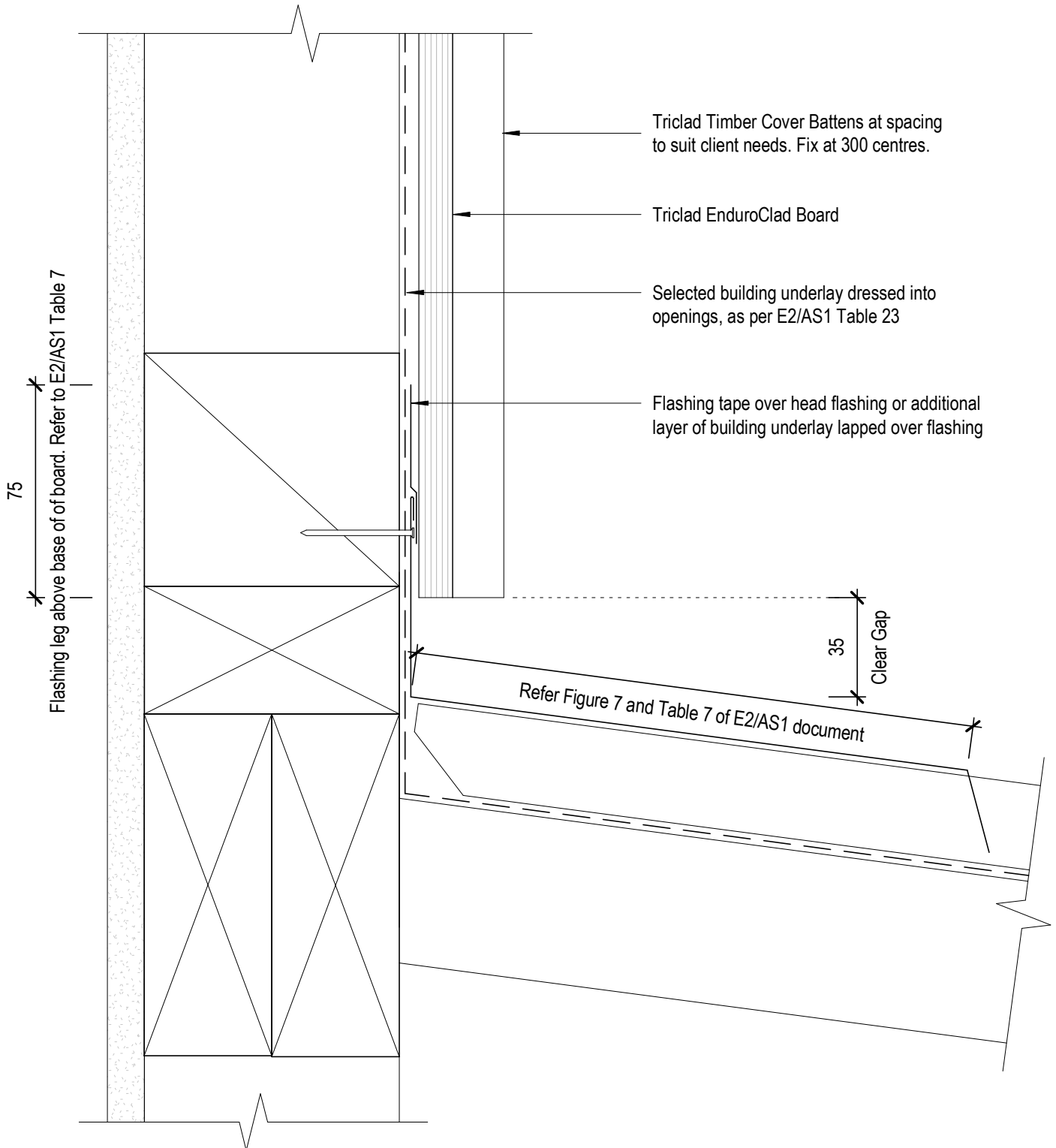

TRICLAD
CLADDING SYSTEMS

8 Quail Place
Hamilton Lake
Hamilton
New Zealand

Direct Fix
Roof/Wall Detail

T. 0800 874 2523

E. sales@triclad.co.nz

www.triclad.co.nz

1 : 2 @ A4
Scale

Dec 2019
Date

Fig 35
Dwg

Triclad EnduroClad

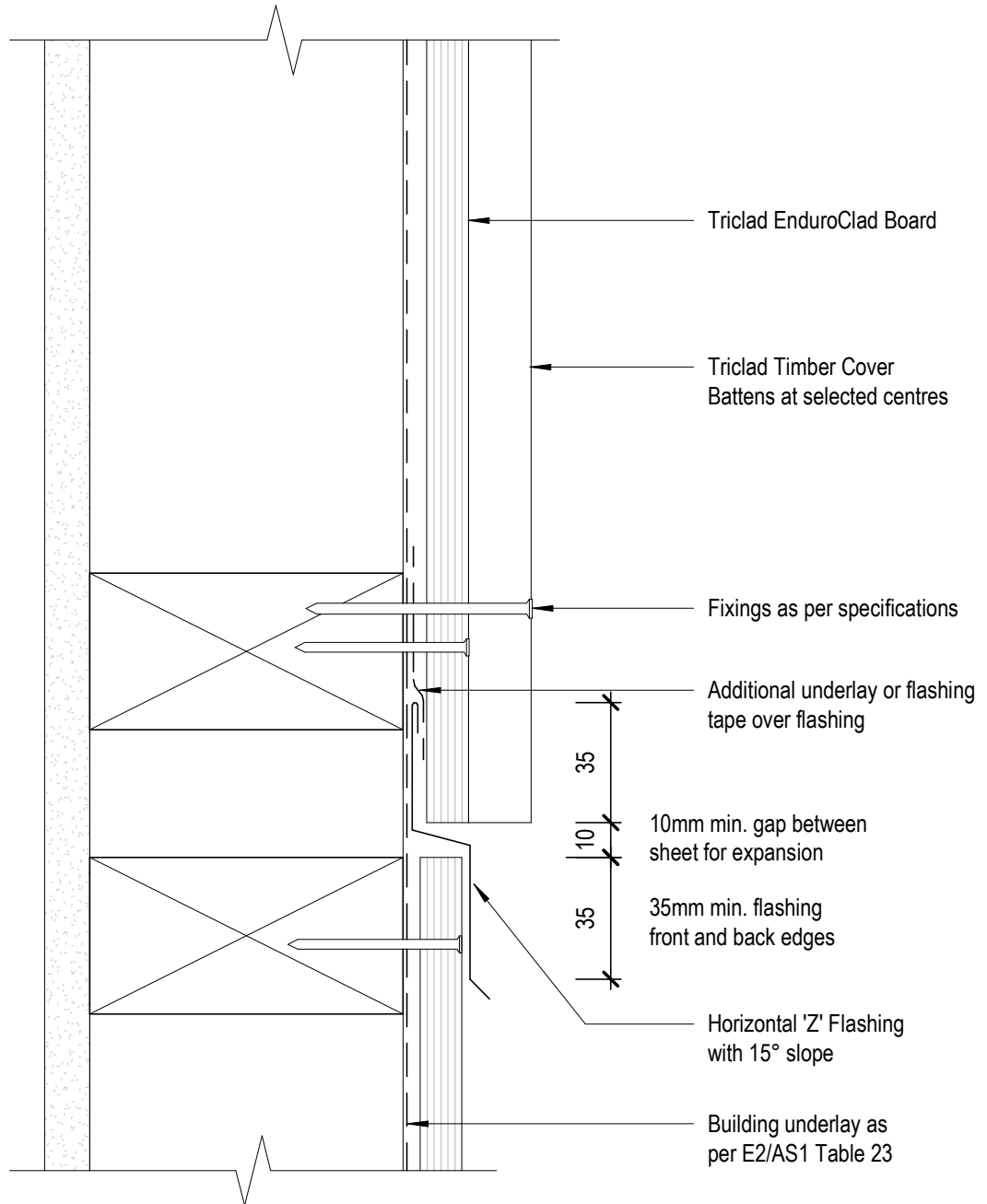

TRICLAD
CLADDING SYSTEMS

8 Quail Place
Hamilton Lake
Hamilton
New Zealand

Direct Fix Horizontal Join Detail

T. 0800 874 2523

E. sales@triclad.co.nz

www.triclad.co.nz

1 : 2 @ A4
Scale

Dec 2019
Date

Fig 36
Dwg

Triclad EnduroClad

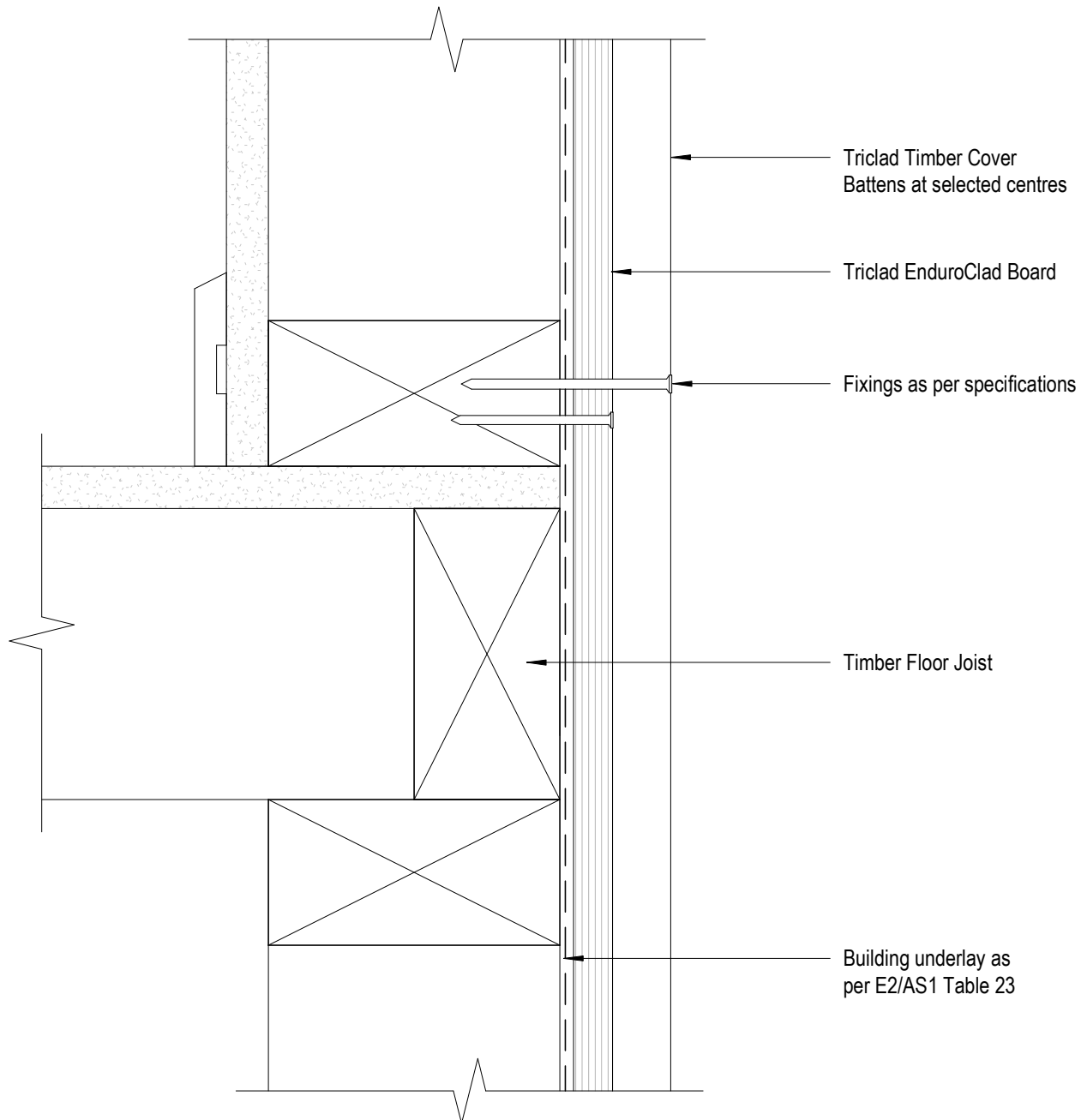

TRICLAD
CLADDING SYSTEMS

8 Quail Place
Hamilton Lake
Hamilton
New Zealand

**Direct Fix
Inter-Story Detail - No Join**

T. 0800 874 2523

E. sales@triclad.co.nz

www.triclad.co.nz

1 : 2 @ A4
Scale

Dec 2019
Date

Fig 36a
Dwg